



- **Better Hygiene, Better Health.**
- We are creating a clean and hygienic environment to your employees and customers. Good hygiene practice is very essential to minimize the spread of illness and prevent infection.



## *Your Air Care &*

## *Hygiene Partner*

- **Pleasant Aroma, Pleasant Smile.**
- We are providing a fresh-smelling environment and leave the pleasant impression to your customers and visitors by eliminate the unpleasant odor.



## ○ **Innovation. Design. Manufacture.**

- Innovation always start with an idea, turned into a new product invention design and manufactured into a product.







Nozomi Marketing Sdn Bhd was established in August 2004, as a leading supplier for household, washroom & Hygiene products in Malaysia and throughout the world.

Our products range consists of air freshener dispensers, aerosol products, tissue dispensers, soap dispensers (normal/auto/foam) mopping buckets (single/double), sanitary bin, floor signage, hand dryers & etc. Our products are widely used in Hotels, Convention Centres, Exhibition Halls, Banks, Offices, Hospitals, Airport, Night Clubs, Homes, Shopping Complex and other places that are suitable. We also offer OEM to International clients or design to their specific requirements.

For sales and marketing activities, our company has engaged dealers and distributors to swiftly handle for our local customers. We also offer OEM to our local supermarket customers like Aeon Co Bhd, Giant Hypermarket & Aeon Big as we are their reliable source supplier for hygiene and car care products. Whereas in the international markets, our company is open to all options such as appointments of distributors and OEM. Throughout the international Exhibition and Trade Fairs we normally will propose and demonstrate our products to the potential customers around the world.

So far we have participated in quite a number of International Showcases organized by MATRADE & other international organization worldwide. MATRADE has about 41 outlets overseas and 5 Domestic branches and we normally get informations on these Trade Fairs through MATRADE HQ and from MATRADE's Trade Commissioners overseas and Directors from the domestic branches.

Since our establishment, Nozomi Marketing has gained its reputation by exporting the products to the related countries and regions such as Middle East, Dubai, Abu Dhabi, Kuwait, Saudi Arabia, Australia, Panama, Lithuania, Russia, Belgium and South and North Asean countries like Vietnam, Taiwan, China, Hong Kong, the United States of America and Brazil.

#### Our Company's Objective Comprises Of :-

- 1) To produce consistent reliable products that are dependable whilst being competitively in price.
- 2) To develop products that are increasingly environmentally friendly during manufacturing and usage.
- 3) To build a name that is synonym and can comply with high standards.

#### The Company's Mission :-

- 1) To build our export network chains and become a major supplier and distributor internationally worldwide and domestically.
- 2) To work closely with our distributors to assist in new designs based on trends, development, marketing and servicing needs.
- 3) To promote the use of cleaner and "greeners" products throughout the world.
- 4) To develop a complete and comprehensive range to washroom accessories for industrial and commercial customers and to our own expectations.

Ensuring customer's satisfaction with good quality products and fair price is our objective with ultimate goal and motto. We welcome international traders for their enquiries and we encourage them to become our business partners domestically and internationally.



## PRODUCT SHOWROOM

Product showroom displayed the complete range of Washroom Hygiene Products and Consumer Goods for house brand and OEM.



S



## FRAGRANCE EVALUATION ROOM

A full floor of 5 evaluation rooms, making into 2 different sizes to simulate the actual usage environment. This evaluation room allowed us to test & validate our fragrance products. A laboratory with aerosol sample preparation facility next to it is quicken the customer's fragrance selection process and shorten the sample preparation lead time.

F

## WAREHOUSE

Our 30,000 sqft full high rise racking facilities warehouse provide sufficient storage space for our local and export goods including raw materials.



W



## ASSEMBLY DEPARTMENT

A fully air conditioned assembly department with Good Manufacturing Practice (GMP) standard facility to ensure the good working environment for our employee. Well trained assembly workers with tight quality control system to ensure only quality products are released into market.

A

## CERTIFICATION

Nozomi are certified with ISO 9001:2008 Quality Management System in Manufacturing and we are working towards Good Manufacturing Practice (GMP) certification.



C



# Contents

## Contents 02

### Air Freshener Dispenser 03 - 11

AZ 500 / 501 LED Air Freshener Dispenser	03
AZ 510 LED / 510 LCD Air Freshener Dispenser	04
AZ 520 LED / 520 LCD Air Freshener Dispenser	05
AZ 540 LED / 540 LCD Air Freshener Dispenser	06
AZ 560 LED Air Freshener Dispenser	07
AZ 570 LCD Air Freshener Dispenser	08
AZ 532 LED Mini Air Freshener Dispenser	09
AZ 601F / 602F Fan Type Air Freshener Dispenser	10
AZS 002 Continuous Scent Diffuser	11

### Aerosol & Fan Refill 12 - 18

Airnergy Metered Spray 300ml (Premium)	12
Scent Force Metered Spray 300ml	13
AZ Metered Spray 300ml (High Quality)	14
Deluxe Metered Spray 300ml (Medium Quality) / AirZone Metered Spray 300ml	15
AirZone Fibre Wick Refill 80g	16
Scent Force Fibre Wick Fragrance Pot / Airnergy Fiber Disc Air Freshener	17
Airnergy Continuous Scent 50g / Airnergy Mini Metered Spray 110ml	18

### Hand Soap Dispenser 19 - 27

AZ 800-T Tube Series Hand Soap Dispenser	19
AR 800-T Tube Series Hand Soap Dispenser	20
AZ 800 Vertical Pump Series Hand Soap Dispenser	21
AR 800 Vertical Pump Series Hand Soap Dispenser	22
AZ 801-T Tube Series Hand Soap Dispenser	23
AZ 1133 Vertical Pump Series Touch Free Dispenser	24
AZ 1010 / 1010A Liquid Soap Dispenser (Horizontal Pump System)	25
AZ 1000 Liquid Soap Dispenser (Horizontal Pump System)	26
Liquid / Foam Soap Dispensing Product	27

## Tissue & Paper Tower Dispenser 28 - 36

AR 1008 Jumbo Roll Tissue Dispenser	28
AZ 1008 Jumbo Roll Tissue Dispenser	29
AZ 1123 Multi-Fold Tissue Dispenser	30
AZ 1220 Multi-Fold Tissue Dispenser	31
AZ 1221 Multi-Fold Tissue Dispenser	32
AZC 003 Multi-Fold Tissue Dispenser	33
AZ 1009 Hygiene Bath Room Tissue Dispenser	34
AZC 009 / AZ 1101 Pop Up Tissue Dispenser	35
AZ 1300 / 1300 A / 1300 M / 1300 M (A) Center Pull Tissue Dispenser	36

## Urinal Hygiene 37 - 40

AZS 012 / AZS 013 Urinal Sanitizer Dispenser	37
AZ 360 / 361 Urinal Screen	38
AZ 1011 Para Deodorant Block	39
AZ 1106 Para Deodorant Triangle Block / AZ 1125 Enzyme Base Bio Tab / Auto Toilet Flush Disinfectant	40

## Hand Dryer 41

AZ 1035 Automatic Hand Dryer	41
------------------------------	----

## Feminine Hygiene 42

AZ 1800 Lady Sanitary Bin	42
---------------------------	----

## Mopping Bucket 43 - 46

AZ 1032 Down Press Wringer Bucket (22 Liter)	43
AZ 1032W Down Press Wringer	44
AZ 1036 Down Press Wringer Double Bucket (23 + 23 Liter)	45
AZ 1033 Down Press Wringer Bucket (28 Liter)	46

## Floor Safety 47 - 48

AZ 1100 Anti Slip Mat	47
AZ 1012 / 1038 Yellow Sign Board	48





## Air Freshener Dispenser

### Provide a fresh environment

Air care is one of the determinants of washroom cleanliness and vital to maintain the hygienic environment and leaves a good impression to the visitors and employees. Our comprehensive range of air freshener dispensers able to provide a fresh-smelling environment to the employees or visitors by eliminate the unpleasant odours and delivers long-lasting fragrance and consistent aroma throughout the whole day.

### AZ 500 / 501 LED Air Freshener Dispenser

#### Product Info

- Up to 6 months battery life per cycle of battery (Depend on setting of spray interval)
- Integrated metal necking for better aerosol can holding
- Suitable to wall mounting or place on flat surface.
- Key locking system to prevent for pilferage
- Optional Day, Night and 24 hours working mode with integrated light sensor.
- Flexible adjustable spray interval setting : 5 to 25 minutes
- On / off mode switch
  - Self-diagnose system to check circuit run properly and fault indicator
  - Low battery indicator light

#### Packaging

Quantity : 30 units / Carton  
 Carton Size : 473(L) x 273(W) x 495(H)  
 CBM : 0.064 / carton  
 Gross Weight : ± 14.0 kgs

#### Specifications

Colour Available : White  
 Can Size : Able to suit most of the market short can & tall can refill  
 Battery : 2 x D size battery (Super Heavy Duty & Above)  
 Material : ABS  
 Product Dimensions : 85(L) x 81(W) x 238(H)

AZ 500 LED

AZ 501 LED



Economical Model

#### Related

Kindly refer to page 12 - 18 for related product options



#### Colour Option

AZ 500 LED

AZ 501 LED



▲ White

▲ White

▲ Internal Structure

#### Product Dimensions

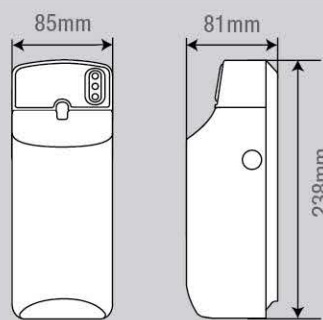

Front View

Side View

#### Specifications

Able to suit short & tall can refill

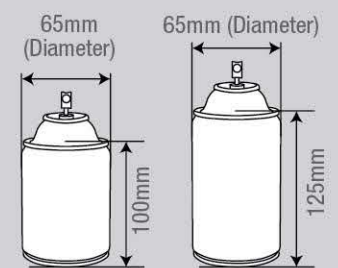

Short Can

Tall Can





## Air Freshener Dispenser

### Provide a fresh environment

Air care is one of the determinants of washroom cleanliness and vital to maintain the hygienic environment and leaves a good impression to the visitors and employees. Our comprehensive range of air freshener dispensers able to provide a fresh-smelling environment to the employees or visitors by eliminate the unpleasant odours and delivers long-lasting fragrance and consistent aroma throughout the whole day.

### AZ 510 LED / 510 LCD Air Freshener Dispenser

#### Product Info AZ 510 LED

- Up to 12 months battery life per cycle of battery (Depend on setting of spray interval)
- Integrated metal necking for better aerosol can holding
- Suitable to wall mounting or place on flat surface.
- Key locking system to prevent for pilferage
- Optional Day, Night and 24 hours working mode with integrated light sensor.
- Adjustable spray interval setting : 5, 10, 15, 25 minutes
- On / off & test mode switch
  - Self-diagnose system to check circuit run properly and fault indicator
  - Low battery indicator light
  - Integrated test mode to conduct spray test instantly

#### Product Info AZ 510 LCD

- Up to 12 months battery life per cycle of battery (Depend on setting of spray interval)
- Integrated metal necking for better aerosol can holding
- Suitable to wall mounting or place on flat surface.
- Key locking system to prevent for pilferage
- Optional 24 hours or customize working hours setting
- Adjustable spray interval setting : 1-99 minutes
- Clock setting available
- Service reminder with up to 9000 sprays setting alert function
- Low battery indicator
- Battery life usage counter (Day)
- Continuous 3 consecutive demo spray test function

#### Specifications

Colour Available	: White
Can Size	: Able to suit most of the market short can refill
Battery	: 2 x AA size battery (Alkaline)
Material	: ABS
Product Dimensions	: 75(L) x 86(W) x 206(H)

#### Packaging

Quantity	: 30 units / Carton
Carton Size	: 487(L) x 454(W) x 232(H)
CBM	: 0.051 / carton
Gross Weight	: ± 12.90 kgs

#### Related

Kindly refer to page 12 - 18 for related product options



#### Colour Option



#### Product Dimensions

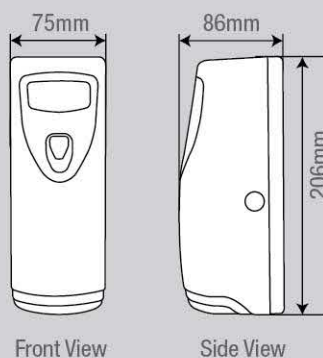

#### Specifications

Able to suit short can refill

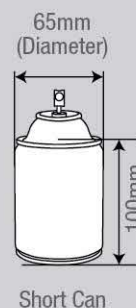





## Air Freshener Dispenser

### Provide a fresh environment

Air care is one of the determinants of washroom cleanliness and vital to maintain the hygienic environment and leaves a good impression to the visitors and employees. Our comprehensive range of air freshener dispensers able to provide a fresh-smelling environment to the employees or visitors by eliminate the unpleasant odours and delivers long-lasting fragrance and consistent aroma throughout the whole day.

### AZ 520 LED / 520 LCD Air Freshener Dispenser

#### Product Info AZ 520 LED

- Up to 12 months battery life per cycle of battery (Depend on setting of spray interval)
- Integrated metal necking for better aerosol can holding
- Suitable to wall mounting or place on flat surface.
- Key locking system to prevent for pilferage
- Optional Day, Night and 24 hours working mode with integrated light sensor.
- Adjustable spray interval setting : 5, 10, 15, 25 minutes
- On / off & test mode switch
  - Self-diagnose system to check circuit run properly and fault indicator
  - Low battery indicator light
  - Integrated test mode to conduct spray test instantly

#### Product Info AZ 520 LCD

- Up to 12 months battery life per cycle of battery (Depend on setting of spray interval)
- Integrated metal necking for better aerosol can holding
- Suitable to wall mounting or place on flat surface.
- Key locking system to prevent for pilferage
- Optional 24 hours or customize working hours setting
- Adjustable spray interval setting : 1-99 minutes
- Clock setting available
- Service reminder with up to 9000 sprays setting alert function
- Low battery indicator
- Battery life usage counter (Day)
- Continuous 3 consecutive demo spray test function



#### Specifications

Colour Available	: White
Can Size	: Able to suit most of the market short can & tall can refill
Battery	: 2 x AA size battery (Alkaline)
Material	: PP
Product Dimensions	: 80(L) x 88(W) x 233(H)

#### Packaging

Quantity	: 30 units / Carton
Carton Size	: 473(L) x 273(W) x 495(H)
CBM	: 0.064 / carton
Gross Weight	: ± 14.0 kgs

#### Related

Kindly refer to page 12 - 18 for related product options



#### Colour Option



#### Product Dimensions

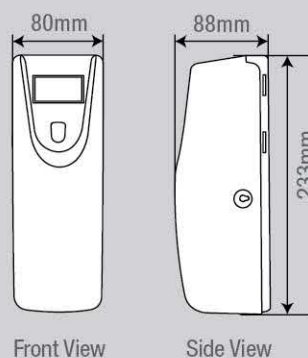

#### Specifications

Able to suit short & tall can refill

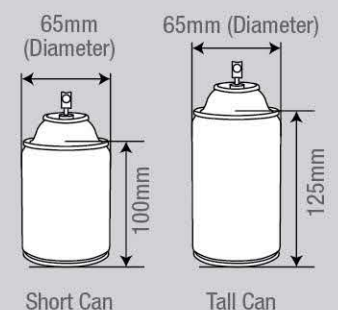





## Air Freshener Dispenser

### Provide a fresh environment

Air care is one of the determinants of washroom cleanliness and vital to maintain the hygienic environment and leaves a good impression to the visitors and employees. Our comprehensive range of air freshener dispensers able to provide a fresh-smelling environment to the employees or visitors by eliminate the unpleasant odours and delivers long-lasting fragrance and consistent aroma throughout the whole day.

### AZ 540 LED / 540 LCD Air Freshener Dispenser

#### Product Info AZ 540 LED

- Up to 12 months battery life per cycle of battery (Depend on setting of spray interval)
- Integrated metal necking for better aerosol can holding
- Suitable to wall mounting or place on flat surface.
- Key locking system to prevent for pilferage
- Optional Day, Night and 24 hours working mode with integrated light sensor.
- Adjustable spray interval setting : 5, 10, 15, 25 minutes
- On / off & test mode switch
  - Self-diagnose system to check circuit run properly and fault indicator
  - Low battery indicator light
  - Integrated test mode to conduct spray test instantly

#### Product Info AZ 540 LCD

- Up to 12 months battery life per cycle of battery (Depend on setting of spray interval)
- Key locking system to prevent for pilferage
- Optional 24 hours or customize working hours setting
- Adjustable spray interval setting : 1-99 minutes
- Clock setting available
- Service reminder with up to 9000 sprays setting alert function
- Low battery indicator
- Battery life usage counter (Day)
- Continuous 3 consecutive demo spray test function

#### Specifications

Colour Available	: White
Can Size	: Able to suit most of the market short can refill
Battery	: 2 x AA size battery (Alkaline)
Material	: ABS
Product Dimensions	: 78(L) x 85(W) x 207(H)

#### Packaging

Quantity	: 30 units / Carton
Carton Size	: 487(L) x 454(W) x 232(H)
CBM	: 0.051 / carton
Gross Weight	: ± 12.90 kgs

#### Related

Kindly refer to page 12 - 18 for related product options



#### Colour Option



#### Product Dimensions

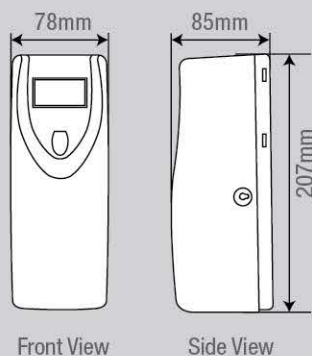

#### Specifications

Able to suit short can refill

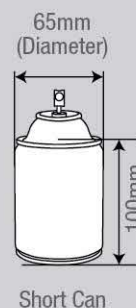





## Air Freshener Dispenser

### Provide a fresh environment

Air care is one of the determinants of washroom cleanliness and vital to maintain the hygienic environment and leaves a good impression to the visitors and employees. Our comprehensive range of air freshener dispensers able to provide a fresh-smelling environment to the employees or visitors by eliminate the unpleasant odours and delivers long-lasting fragrance and consistent aroma throughout the whole day.

### AZ 560 LED Air Freshener Dispenser

#### Product Info :

- Simple and economical model
- Suitable to wall mounting or place on flat surface.
- Up to 3 months battery life per cycle of battery
- Non-stop 24 hours fragrance spray
- Adjustable spray interval setting : 8, 15, 25 minutes
- Easy operate top press button to open the dispenser cover

#### Packaging :

Quantity : 30 units / Carton  
 Carton Size : 463(L) x 313(W) x 416(H)  
 CBM : 0.060 / carton  
 Gross Weight : ± 13.23 kgs

#### Specifications :

Colour Available : White  
 Can Size : Able to suit most of the market short can refill  
 Battery : 2 x AA size battery (Alkaline)  
 Material : PP  
 Product Dimensions : 86(L) x 82(W) x 200(H)

#### Related

Kindly refer to page 12 - 18 for related product options



#### Colour Option



▲ White



▲ Internal Structure

#### Product Dimensions

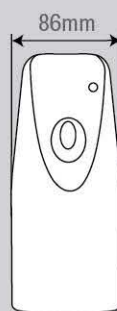

Front View

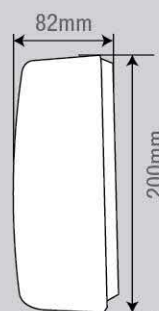

Side View

#### Specifications

Able to suit short can refill

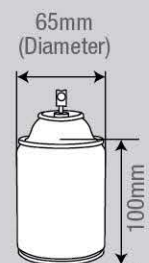

Short Can





## Air Freshener Dispenser

### Provide a fresh environment

Air care is one of the determinants of washroom cleanliness and vital to maintain the hygienic environment and leaves a good impression to the visitors and employees. Our comprehensive range of air freshener dispensers able to provide a fresh-smelling environment to the employees or visitors by eliminate the unpleasant odours and delivers long-lasting fragrance and consistent aroma throughout the whole day.

### AZ 570 LCD Air Freshener Dispenser

#### Product Info

- Up to 12 months battery life per cycle of battery (Depend on setting of spray interval)
- Suitable to wall mounting or place on flat surface.
- Key locking system to prevent for pilferage
- Day off programming capability
- Adjustable spray interval setting : 0-60 minutes
- Clock setting available
- Service reminder with up to 9000 sprays setting alert function
- Low battery indicator
- Battery life usage counter (Day)

#### Packaging

Quantity : 30 units / Carton  
 Carton Size : 473(L) x 273(W) x 495(H)  
 CBM : 0.064 / carton  
 Gross Weight : ± 14.0 kgs

#### Specifications

Colour Available : White  
 Can Size : Able to suit most of the market short can refill  
 Battery : 2 x D size battery (Alkaline)  
 Material : PP  
 Product Dimensions : 90(L) x 83(W) x 215(H)

#### Related

Kindly refer to page 12 - 18 for related product options



#### Colour Option



▲ White



▲ Internal Structure

#### Product Dimensions

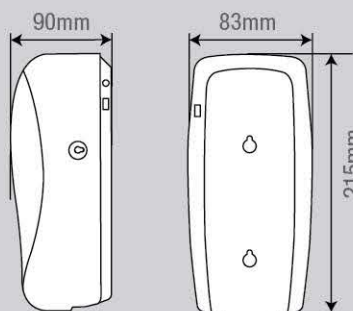

Front View

Side View

#### Specifications

Able to suit short can refill

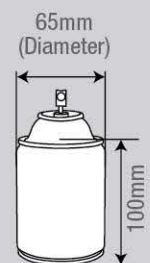

Short Can





## Air Freshener Dispenser

### Provide a fresh environment

Air care is one of the determinants of washroom cleanliness and vital to maintain the hygienic environment and leaves a good impression to the visitors and employees. Our comprehensive range of air freshener dispensers able to provide a fresh-smelling environment to the employees or visitors by eliminate the unpleasant odours and delivers long-lasting fragrance and consistent aroma throughout the whole day.

### AZ 532 LED Mini Air Freshener Dispenser

#### Product Info :

- Up to 3 months battery life per cycle of battery (Depend on setting of spray interval)
- Suitable to wall mounting or place on flat surface.
- Key locking system to prevent for pilferage
- Optional Day, Night and 24 hours working mode with integrated light sensor.
- Adjustable spray interval setting : 5, 10, 15, 25 minutes
- On / off mode switch
  - Self-diagnose system to check circuit run properly and fault indicator
  - Low battery indicator light

#### Packaging :

Quantity : 30 units / Carton  
 Carton Size : 342(L) x 285(W) x 374(H)  
 CBM : 0.036 / carton  
 Gross Weight : ± 9.77 kgs

#### Specifications :

Colour Available : White  
 Can Size : Able to suit most of the market aluminum can or metal can mini refill  
 Battery : 2 x C size battery (Super Heavy Duty & Above)  
 Material : PP (Cover) & ABS (Base)  
 Product Dimensions : 83(L) x 58(W) x 167(H)



#### Related

Kindly refer to page 12 - 18 for related product options



#### Colour Option



▲ White



▲ Internal Structure

#### Product Dimensions



Front View

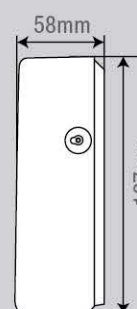

Side View

#### Specifications

Able to suit mini can refill

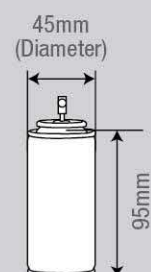

Mini Can





# Air Freshener Dispenser

## Provide a fresh environment

Air care is one of the determinants of washroom cleanliness and vital to maintain the hygienic environment and leaves a good impression to the visitors and employees. Our comprehensive range of air freshener dispensers able to provide a fresh-smelling environment to the employees or visitors by eliminate the unpleasant odours and delivers long-lasting fragrance and consistent aroma throughout the whole day.

### AZ 601F / 602F Fan Type Air Freshener Dispenser

#### Product Info AZ 601F

- Up to 2 months battery life per cycle of battery (Depend on setting of operation)
- Key locking system to prevent for pilferage
- Able to suit most of the market refill
- Optional Day, Night and 24 hours working mode with integrated light sensor.
- Multiple Operation Mode to suit different type of refill :
  - Non-stop ● 2 min ON 1 min OFF ● 1 min ON 1 min OFF ● 1 min ON 2 min OFF
- Fan blowing speed up to 650 rpm
- Power indicator : Batteries are working when the green light is flashing

#### Specifications

Colour Available : White  
 Battery : 1 x D size battery (Super Heavy Duty & Above)  
 Material : ABS  
 Product Dimensions : 90(L) x 89(W) x 196(H)

#### Product Info AZ 602F

- Up to 2 months battery life per cycle of battery (Depend on setting of operation)
- Key locking system to prevent for pilferage
- Able to suit most of the market refill
- Optional Day, Night and 24 hours working mode with integrated light sensor.
- Multiple Operation Mode to suit different type of refill:
  - 8 Weeks Cycle\*\* ● 30 Sec ON 30 Sec OFF ● 30 Sec ON 60 Sec OFF, ● 30 Sec ON 90 Sec OFF,

\*\* 8 weeks progressive operation time mode. Low operation at initial cycle and high operation at the end of cycle.

- Fan blowing speed up to 1200 rpm
- Power indicator : Batteries are working when the blue light is flashing

#### Specifications

Colour Available : White  
 Battery : 2 x D size battery (Super Heavy Duty & Above)  
 Material : ABS  
 Product Dimensions : 90(L) x 89(W) x 196(H)

AZ 601F

AZ 602F



#### Packaging

Quantity : 30 units / Carton  
 Carton Size : 463(L) x 313(W) x 416(H)  
 CBM : 0.060 / carton  
 Gross Weight : ± 13.23 kgs

#### Related

Kindly refer to page 12 - 18 for related product options



#### Colour Option

#### Product Dimensions



#### Colour Option

#### Product Dimensions

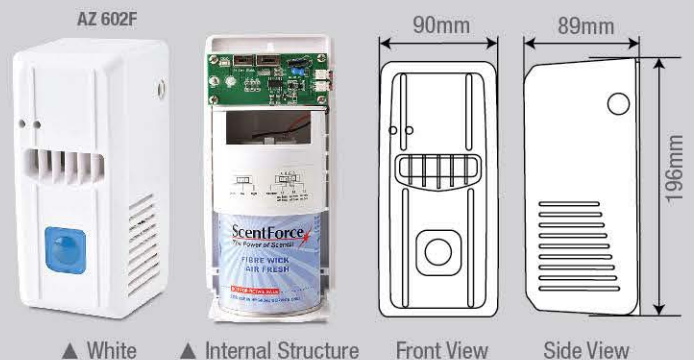





## Air Freshener Dispenser

### Provide a fresh environment

Air care is one of the determinants of washroom cleanliness and vital to maintain the hygienic environment and leaves a good impression to the visitors and employees. Our comprehensive range of air freshener dispensers able to provide a fresh-smelling environment to the employees or visitors by eliminate the unpleasant odours and delivers long-lasting fragrance and consistent aroma throughout the whole day.

### AZS 002 Continuous Scent Diffuser

#### Product Info

- Small and stylish design
- Capillary Action Continuous fragrance delivery system
- User friendly in changing refill.
- Wide coverage area. Up to 1300 cubic feet per refill
- Environmental friendly. Much more lower VOC as compared to aerosol air freshener.
- Battery free operation. Create less battery waste.
- Recycle friendly as compared to aerosol air freshener

#### Packaging

Quantity : 24 units / Carton  
 Carton Size : 441(L) x 297(W) x 153(H)  
 CBM : 0.020 / carton  
 Gross Weight : ± 1.838 kgs

#### Specifications

Colour Available : White  
 Material : PP  
 Product Dimensions : 70(L) x 70(W) x 140(H)

#### Related

Kindly refer to page 12 - 18 for related product options



#### Colour Option



▲ White



▲ Internal Structure

#### Product Dimensions

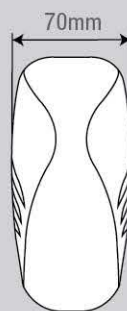

Front View

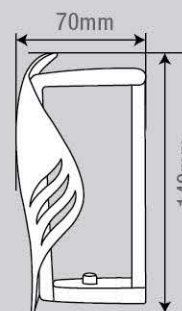

Side View

#### Specifications

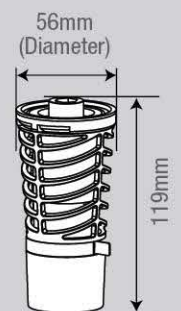

Continuous Scent Refill





## Aerosol & Fan Refill

### Choose your perfect scent with available fragrance selection

Our wide range of fragrance selection library more than 150 types of fragrance able to meet different market segment and preference. You are able to choose your perfect scent with available fragrance selection.

### AZ 1029 Airnergy Metered Spray 300ml (Premium)

AZ 1029



#### Product Info

- Short can with High Cone
- Up to 3000 spray per refill for 1 month usage
- Premium Quality. Long lasting fragrance with natural essential oil
- CFC free propellant
- Multiple actuator design to suit different market dispenser (upon request)
- Using fragrance with European standard with international compliance such as IFRA, REACH & allergen
- Fragrance customization available with huge library selection.

#### Packaging

Quantity : 24 cans / Carton  
 Carton Size : 407(L) x 270(W) x 153(H)  
 CBM : 0.017 / carton  
 Gross Weight : ± 6.70 kgs

#### Related

Kindly refer to page 03 - 11 for related product options



#### Product Dimensions

65mm (Diameter)

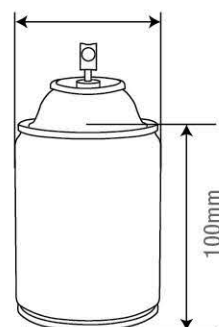

Short Can

#### Specifications

Can Size : Short can with high cone  
 Product Dimensions : 65mm (Diameter) x 100mm (H)  
 Fragrances : • Citrus Zest • Lavender • Vanilla Bouquet • Potpourri • Green Tea • Lemon  
 - Able customize your own fragrance





## Aerosol & Fan Refill

### Choose your perfect scent with available fragrance selection

Our wide range of fragrance selection library more than 150 types of fragrance able to meet different market segment and preference. You are able to choose your perfect scent with available fragrance selection.

### Scent Force Metered Spray 300ml (Short Can)

#### Product Info

- Up to 3000 sprays per refill for 1 month usage
- High Grade Quality.
- CFC free propellant
- Multiple actuator design to suit different market dispenser (upon request)
- Using fragrance with European standard with international compliance such as IFRA, REACH & allergen
- Fragrance customization available with huge library selection.

#### Packaging

Quantity : 24 cans / Carton  
 Carton Size : 407(L) x 270(W) x 153(H)  
 CBM : 0.017 / carton  
 Gross Weight : ± 6.8 kgs

#### Related

Kindly refer to page 03 - 11 for related product options



#### Specifications

Can Size : Short can with high cone  
 Product Dimensions : 65mm (Diameter) x 100mm (H)  
 Fragrances : • Lemon • Lavender • Mix Floral • CK • Polo  
 • Vanilla Bouquet • Potpourri • Apple Blossom  
 - **Able customize your own fragrance**



#### Product Dimensions

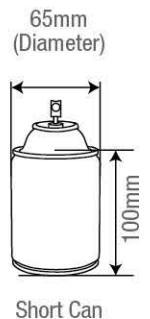

### Scent Force Metered Spray 300ml (Tall Can)

#### Product Info

- High Grade Quality.
- CFC free propellant
- Multiple actuator design to suit different market dispenser (upon request)
- Using fragrance with European standard with international compliance such as IFRA, REACH & allergen
- Fragrance customization available with huge library selection.

#### Packaging

Quantity : 24 cans / Carton  
 Carton Size : 410(L) x 270(W) x 172(H)  
 CBM : 0.019 / carton  
 Gross Weight : ± 7.0 kgs

#### Related

Kindly refer to page 03 - 11 for related product options



#### Specifications

Can Size : Short can with high cone  
 Product Dimensions : 65mm (Diameter) x 125mm (H)  
 Fragrances : • Lemon • Lavender • Vanilla Bouquet  
 - **Able customize your own fragrance**



#### Product Dimensions

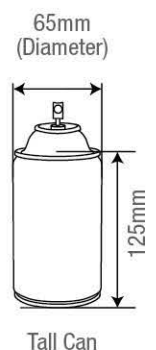





## Aerosol & Fan Refill

### Choose your perfect scent with available fragrance selection

Our wide range of fragrance selection library more than 150 types of fragrance able to meet different market segment and preference. You are able to choose your perfect scent with available fragrance selection.

### AZ Metered Spray 300ml (Short Can) (High Quality)

#### Product Info

- Up to 3000 sprays per refill for 1 month usage
- High Grade Quality.
- CFC free propellant
- Multiple actuator design to suit different market dispenser (upon request)
- Using fragrance with European standard with international compliance such as IFRA, REACH & allergen
- Fragrance customization available with huge library selection.

#### Packaging

Quantity : 24 cans / Carton  
 Carton Size : 407(L) x 270(W) x 150(H)  
 CBM : 0.016 / carton  
 Gross Weight : ± 6.8 kgs

#### Related

Kindly refer to page 03 - 11 for related product options



#### Specifications

Can Size : Short can with high cone  
 Product Dimensions : 65 (Diameter) x 100(H)  
 Fragrances : • Citrus • Lemon • Orange • Lavender  
 • Vanilla Bouquet • Country Garden • Sparkling Lemon  
 - Able customize your own fragrance

AZ 290



#### Product Dimensions

65mm (Diameter)

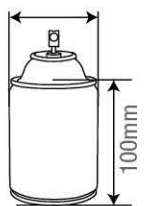

Short Can

### AZ Metered Spray 300ml (Tall Can) (High Quality)

#### Product Info

- Up to 3000 sprays per refill for 1 month usage
- High Grade Quality.
- CFC free propellant
- Multiple actuator design to suit different market dispenser (upon request)
- Using fragrance with European standard with international compliance such as IFRA, REACH & allergen
- Fragrance customization available with huge library selection.

#### Packaging

Quantity : 24 cans / Carton  
 Carton Size : 410(L) x 270(W) x 172(H)  
 CBM : 0.019 / carton  
 Gross Weight : ± 7.0 kgs

#### Related

Kindly refer to page 03 - 11 for related product options



#### Specifications

Can Size : Tall can with normal cone  
 Product Dimensions : 65 (Diameter) x 125(H)  
 Fragrances : • Citrus • Lemon • Orange • Lavender  
 • Vanilla Bouquet • Country Garden • Sparkling Lemon  
 - Able customize your own fragrance

AZ 300



#### Product Dimensions

65mm (Diameter)

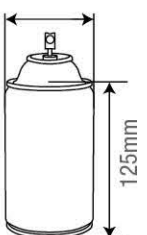

Tall Can





## Aerosol & Fan Refill

### Choose your perfect scent with available fragrance selection

Our wide range of fragrance selection library more than 150 types of fragrance able to meet different market segment and preference. You are able to choose your perfect scent with available fragrance selection.

### Deluxe Metered Spray 300ml (Medium Quality)

#### Product Info

- Up to 3000 sprays per refill for 1 month usage
- Medium Grade Quality.
- CFC free propellant
- Multiple actuator design to suit different market dispenser (upon request)
- Using fragrance with European standard with international compliance such as IFRA, REACH & allergen
- Fragrance customization available with huge library selection.

#### Related

Kindly refer to page 03 - 11 for related product options



#### Product Dimensions

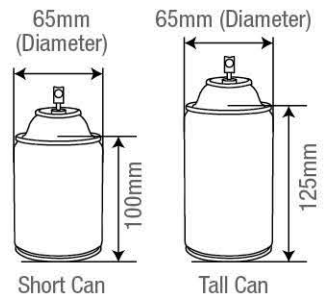

#### Packaging AZ 1136 Deluxe (Short Can)

- Quantity : 24 cans / Carton  
 Carton Size : 407(L) x 270(W) x 150(H)  
 CBM : 0.016 / carton  
 Gross Weight : ± 6.8 kgs

AZ 1136



#### Packaging AZ 1137 Deluxe (Tall Can)

- Quantity : 24 cans / Carton  
 Carton Size : 410(L) x 270(W) x 172(H)  
 CBM : 0.019 / carton  
 Gross Weight : ± 7.0 kgs

AZ 1137



#### Specifications AZ 1136 Deluxe (Short Can)

- Can Size : Short can with high cone  
 Product Dimensions : 65 (Diameter) x 100(H)  
 Fragrances : • Citrus Zest • Lavender  
 • Vanilla Bouquet • Potpourri  
 - Able customize your own fragrance

#### Specifications AZ 1137 Deluxe (Tall Can)

- Can Size : Tall can with normal cone  
 Product Dimensions : 65 (Diameter) x 125(H)  
 Fragrances : • Citrus Zest • Lavender  
 • Vanilla Bouquet • Potpourri  
 - Able customize your own fragrance

### AirZone Metered Spray 300ml (Tall Can)

#### Product Info

- Up to 3000 sprays per refill for 1 month usage
- High Grade Quality.
- CFC free propellant
- Multiple actuator design to suit different market dispenser (upon request)
- Using fragrance with European standard with international compliance such as IFRA, REACH & allergen
- Fragrance customization available with huge library selection.

#### Packaging

- Quantity : 24 cans / Carton  
 Carton Size : 410(L) x 270(W) x 172(H)  
 CBM : 0.019 / carton  
 Gross Weight : ± 7.0 kgs

#### Related

Kindly refer to page 03 - 11 for related product options



#### AirZone Metered Spray 300ml



#### Product Dimensions

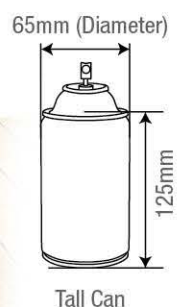

#### Specifications

- Can Size : Tall can with high cone  
 Product Dimensions : 65 (Diameter) x 125(H)  
 Fragrances : • Lemon • Lavender • CK • Vanilla Bouquet • Meadow  
 - Able customize your own fragrance





## Aerosol & Fan Refill

### Choose your perfect scent with available fragrance selection

Our wide range of fragrance selection library more than 150 types of fragrance able to meet different market segment and preference. You are able to choose your perfect scent with available fragrance selection.

### AirZone Fibre Wick Refill 80g

AZ 1132



#### Product Info

- Able to fit in most of the market fan type dispenser
- Strong impact fragrance delivery system for those who like strong.
- Premium fibre wick for long lasting fragrance with natural peel extracts and air freshening
- Up to 30 days usage life (Depending on Fan setting)
- Using fragrance with European standard with international compliance such as IFRA, REACH & allergen

#### Packaging

Quantity : 24 cans / Carton  
 Carton Size : 275(L) x 208(W) x 142(H)  
 CBM : 0.008 / carton  
 Gross Weight : ± 2.40 kgs

#### Related

Kindly refer to page 03 - 11 for related product options



#### Product Dimensions

65mm (Diameter)

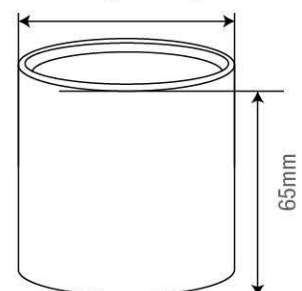

#### Specifications

Product Dimensions : 65mm (Diameter) x 65mm (H)

Popular Fragrances : • Floral • Aqua • Citrus • Lavender • Fresh Lemon  
 • Fruit Exotique • Vanilla Bouquet • Tropical Mango • Orchard Blush  
 - Able customize your own fragrance





## Aerosol & Fan Refill

### Choose your perfect scent with available fragrance selection

Our wide range of fragrance selection library more than 150 types of fragrance able to meet different market segment and preference. You are able to choose your perfect scent with available fragrance selection.

### Scent Force Fibre Wick Fragrance Pot

#### Product Info

- Able to fit in most of the market fan type dispenser
- Slow release and consistent fragrance delivery system
- Premium fibre wick for long lasting fragrance with natural peel extracts and air freshening
- Up to 30 days usage life (Depending on Fan setting)
- Using fragrance with European standard with international compliance such as IFRA, REACH & allergen

#### Packaging

Quantity : 24 cans / Carton  
 Carton Size : 275(L) x 208(W) x 142(H)  
 CBM : 0.008 / carton  
 Gross Weight : ± 2.40 kgs

#### Related

Kindly refer to page 03 - 11 for related product options



#### Specifications

Product Dimensions : 65 (Diameter) x 67(H)  
 Popular Fragrances : • Blue Splash • Waterfall • Mandarin Orange • Citrus  
 • Linen Fresh • Radiant • Hemisphere • Kiwi  
 • Lavender • Vanilla Bouquet • Havana  
 - Able customize your own fragrance

AZ 1135



#### Product Dimensions

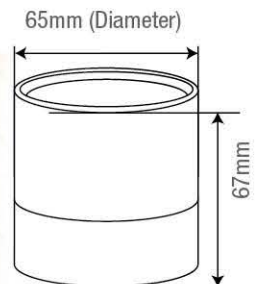

### AZ 1155 Airnergy Fiber Disc Air Freshener

#### Product Info

- Able to fit in most of the market fan type dispenser
- Air freshener was enhanced with twin side evaporation system which could deliver the fragrance more effectively
- Up to 30 days usage life (Depending on Fan setting)
- Using fragrance with European standard with international compliance such as IFRA, REACH & allergen

#### Packaging

Quantity : 24 cans / Carton  
 Carton Size : 417(L) x 250(W) x 78(H)  
 CBM : 0.081 / carton  
 Gross Weight : ± 2.40 kgs

#### Related

Kindly refer to page 03 - 11 for related product options



#### Specifications

Product Dimensions : 60 (Diameter) x 70(H)  
 Popular Fragrances : • Delicate Floral • Vanilla Bouquet  
 • Hemisphere • Mandarin Orange  
 - Able customize your own fragrance

AZ 1155



#### Product Dimensions

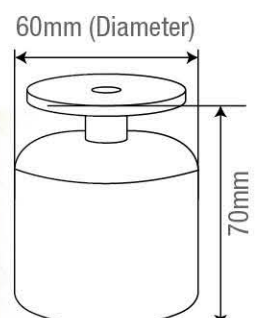





## Aerosol & Fan Refill

### Choose your perfect scent with available fragrance selection

Our wide range of fragrance selection library more than 150 types of fragrance able to meet different market segment and preference. You are able to choose your perfect scent with available fragrance selection.

### AZ S011 Airnergy Continuous Scent 50g

#### Product Info

- Capillary action Self-evaporation system enable to deliver the fragrance continuously
- Up to 30 days usage life
- Silent & Battery Free operation dispenser
- VOC-less fragrance delivery system
- Using fragrance with European standard with international compliance such as IFRA, REACH & allergen

▼ Blue Splash    ▼ Mandarin Orange    ▼ Mango Blossom



#### Product Dimensions

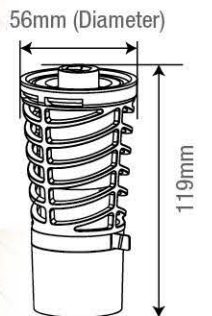

#### Packaging

Quantity : 24 units / Carton  
 Carton Size : 347(L) x 234(W) x 125(H)  
 CBM : 0.010 / carton  
 Gross Weight : ± 2.584 kgs

#### Related

Kindly refer to page 03 - 11 for related product options



▼ Summer Flower    ▼ Waterfall



AZ S011 Airnergy Continuous Scent Refill 40/50g

#### Specifications

Product Dimensions : 56mm (Diameter) x 119mm (H)  
 Fragrances : • Blue Splash • Summer Flower • Waterfall  
                   • Mango Blossom • Mandarin Orange  
 - Able customize your own fragrance

### AZ 1027 Airnergy Mini Metered Spray 110ml

#### Product Info

- Up to 3000 spray per refill for 1 month usage
- Long lasting fragrance with natural essential oil
- CFC free propellant
- Multiple actuator design to suit different market dispenser (upon request)
- Using fragrance with European standard with international compliance such as IFRA, REACH & allergen
- Fragrance customization available with huge library selection.



#### Product Dimensions

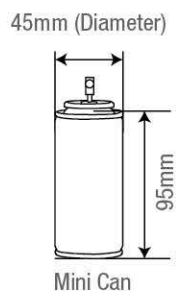

AZ 1027 Airnergy Mini Metered Spray Refill 110ml

#### Packaging

Quantity : 24 cans / Carton  
 Carton Size : 280(L) x 189(W) x 133(H)  
 CBM : 0.007 / carton  
 Gross Weight : ± 2.85 kgs

#### Specifications

Can Size : Mini can with mini cone  
 Product Dimensions : 45mm (Diameter) x 95mm (H)  
 Fragrances : • Citrus Zest • Lemon • Lavender • Vanilla Bouquet  
                   • Apple Blossom • Vibrant • Impression • Expression  
                   • Radiant • Tranquil • Ice age  
 - Able customize your own fragrance

#### Related

Kindly refer to page 03 - 11 for related product options







## Hand Soap Dispenser

### Hand washing

Promoting the hand hygiene practice to reduce the cross-contamination and prevent the spread of illness. Our range of hand soap dispensers with different type of dispensing system able to provide customer comprehensive hand hygiene solution and improving the hand hygiene level to users.

## AZ 800-T Tube Series Hand Soap Dispenser

### Product Info

- Stylist, slim and compact design
- Equip with refillable container with lid
- Dispenser made from 100% virgin material to ensure durability
- Durable tube system with high grade silicon tube
- Soap level viewing window
- Hidden keyless lock system
- Optional transparent cover for easy soap usage level viewing

### Packaging

Quantity : 30 units / Carton  
 Carton Size : 456(L) x 430(W) x 497(H)  
 CBM : 0.097 / carton  
 Gross Weight : ± 13.26 kgs

### Specifications

Color Available : White / Transparent Dark Blue  
 Material : ABS  
 Capacity : 800ml  
 Product Dimensions : 133(L) x 88(W) x 237(H)  
 Type : Tube System

### Related

Kindly refer to page 19 - 27 for related product options



AZ 800-T



### Multiple Dispensing Systems

Model 1 AZ 800-T

#### Liquid Soap



Dispensing Volume : 0.40ml per shot

Model 2 AZ 800-T-HS

#### HAND SANITIZER



Dispensing Volume : 0.40ml per shot

### Colour Option



▲ White



▲ Transparent Blue

### Product Dimensions

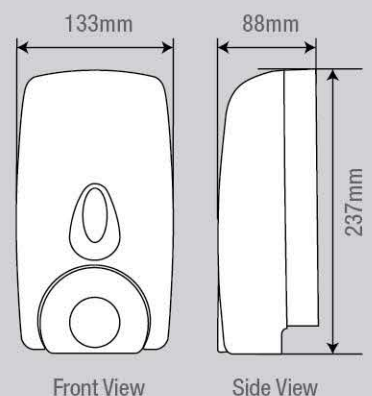





# Hand Soap Dispenser



## Hand washing

Promoting the hand hygiene practice to reduce the cross-contamination and prevent the spread of illness. Our range of hand soap dispensers with different type of dispensing system able to provide customer comprehensive hand hygiene solution and improving the hand hygiene level to users.

### AR 800-T Tube Series Hand Soap Dispenser

#### Product Info

- Contemporary, slim and compact design
- Equip with refillable container with lid
- Dispenser made from 100% virgin material to ensure durability
- Durable tube system with high grade silicon tube
- Soap level viewing window
- Hidden keyless lock system
- Optional transparent cover for easy soap usage level viewing

#### Packaging

Quantity : 30 units / Carton  
 Carton Size : 456(L) x 430(W) x 497(H)  
 CBM : 0.097 / carton  
 Gross Weight : ± 13.26 kgs

#### Specifications

Color Available : White / Transparent Dark Blue  
 Material : ABS  
 Capacity : 800ml  
 Product Dimensions : 134(L) x 88(W) x 237(H)  
 Type : Tube System

#### Related

Kindly refer to page 19 - 27 for related product options



AR 800-T

#### Multiple Dispensing Systems

Model 1 AR 800-T

#### Liquid Soap



Dispensing Volume : 0.40ml per shot

Model 2 AR 800-T-HS

#### HAND SANITIZER

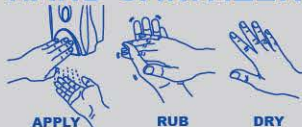

Dispensing Volume : 0.40ml per shot

#### Colour Option



▲ White

▲ Transparent Dark Blue

#### Product Dimensions

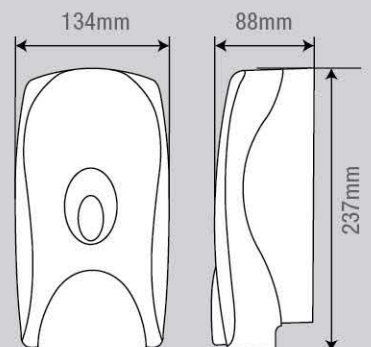

Front View

Side View





## Hand Soap Dispenser

### Hand washing

Promoting the hand hygiene practice to reduce the cross-contamination and prevent the spread of illness. Our range of hand soap dispensers with different type of dispensing system able to provide customer comprehensive hand hygiene solution and improving the hand hygiene level to users.

## AZ 800 Vertical Pump Series Hand Soap Dispenser

### Product Info

- Stylist, slim and compact design
- Equip with refillable container with lid
- Dispenser made from 100% virgin material to ensure durability
- Durable vertical pump system can last up to 100k press
- Soap level viewing window
- Hidden keyless lock system
- Optional transparent cover for easy soap usage level viewing

### Packaging

Quantity : 30 units / Carton  
 Carton Size : 456(L) x 430(W) x 497(H)  
 CBM : 0.097 / carton  
 Gross Weight : ± 13.26 kgs

### Specifications

Color Available : White / Transparent Blue  
 Material : ABS  
 Capacity : 800ml  
 Product Dimensions : 133(L) x 88(W) x 237(H)  
 Type : Pump System

### Related

Kindly refer to page 19 - 27 for related product options



AZ 800



### Multiple Dispensing System

Model 1 AZ 800-L4

#### Liquid Soap



Dispensing Volume : 0.70ml per shot

Model 2 AZ 800-F

#### FOAM SOAP



Dispensing Volume : 0.50ml per shot

Model 3 AZ 800-L4-HS

#### HAND SANITIZER

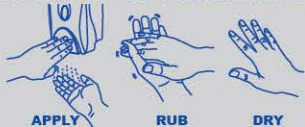

Dispensing Volume : 0.70ml per shot

Model 4 AZ 800-M-TSC

#### TOILET SEAT CLEANER



Dispensing Volume : 0.30ml per shot

### Colour Option



▲ White

▲ Transparent Blue

### Product Dimensions

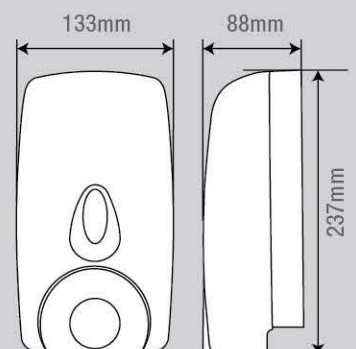

Front View

Side View





# Hand Soap Dispenser



## Hand washing

Promoting the hand hygiene practice to reduce the cross-contamination and prevent the spread of illness. Our range of hand soap dispensers with different type of dispensing system able to provide customer comprehensive hand hygiene solution and improving the hand hygiene level to users.

### AR 800 Vertical Pump Series Hand Soap Dispenser

#### Product Info

- Contemporary, slim and compact design
- Equip with refillable container with lid
- Dispenser made from 100% virgin material to ensure durability
- Durable vertical pump system can last up to 100k press
- Soap level viewing window
- Hidden keyless lock system
- Optional transparent cover for easy soap usage level viewing

#### Packaging

Quantity : 30 units / Carton  
 Carton Size : 456(L) x 430(W) x 497(H)  
 CBM : 0.097 / carton  
 Gross Weight : ± 13.26 kgs

#### Specifications

Color Available : White / Transparent Dark Blue  
 Material : ABS  
 Capacity : 800ml  
 Product Dimensions : 134(L) x 88(W) x 237(H)  
 Type : Pump System

#### Related

Kindly refer to page 19 - 27 for related product options



Multiple Dispensing System		Colour Option	Product Dimensions	
<p><b>Model 1</b> AR 800-L4</p> <p><b>Liquid Soap</b></p> <p>Dispensing Volume : 0.70ml per shot</p>	<p><b>Model 2</b> AR 800-F</p> <p><b>FOAM SOAP</b></p> <p>Dispensing Volume : 0.50ml per shot</p>	<p>▲ White    ▲ Transparent Dark Blue</p>	<p>134mm    88mm</p> <p>237mm</p> <p>Front View    Side View</p>	
<p><b>Model 3</b> AR 800-L4-HS</p> <p><b>HAND SANITIZER</b></p> <p>APPLY    RUB    DRY</p> <p>Dispensing Volume : 0.70ml per shot</p>	<p><b>Model 4</b> AR 800-M-TSC</p> <p><b>TOILET SEAT CLEANER</b></p> <p>Dispensing Volume : 0.30ml per shot</p>			





## Hand Soap Dispenser

### Hand washing

Promoting the hand hygiene practice to reduce the cross-contamination and prevent the spread of illness. Our range of hand soap dispensers with different type of dispensing system able to provide customer comprehensive hand hygiene solution and improving the hand hygiene level to users.

## AZ 801-T Tube Series Hand Soap Dispenser

### Product Info

- Stylist, mini and compact design
- Equip with bulk refill container with lid
- Dispenser made from 100% virgin material to ensure durability
- Durable tube system with high grade silicon tube
- Soap level viewing window
- Hidden keyless lock system

### Packaging

Quantity : 30 units / Carton  
 Carton Size : 417(L) x 352(W) x 403(H)  
 CBM : 0.059 / carton  
 Gross Weight : ± 11.12 kgs

### Specifications

Color Available : White  
 Material : ABS  
 Capacity : 400ml  
 Product Dimensions : 109(L) x 73(W) x 192(H)  
 Type : Tube System

AZ 801-T



### Multiple Dispensing Systems

Model 1 AZ 801-T

**Liquid Soap**



Dispensing Volume : 0.25ml per shot

Model 2 AZ 801-T-HS

**HAND SANITIZER**



Dispensing Volume : 0.25ml per shot

### Colour Option



▲ White

### Product Dimensions

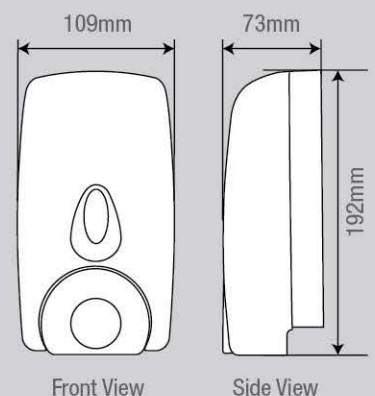





# Hand Soap Dispenser



## Hand washing

Promoting the hand hygiene practice to reduce the cross-contamination and prevent the spread of illness. Our range of hand soap dispensers with different type of dispensing system able to provide customer comprehensive hand hygiene solution and improving the hand hygiene level to users.

### AZ 1133 Vertical Pump Series Touch Free Dispenser

#### Product Info

- Stylist, slim and compact design
- Dual refill system : Bulk refill container / Disposable cartridge with integrated dispensing pump
- Touch free feature able to enhanced hygiene and reduce cross contamination
- Able to fit multiple pump head to dispense different type of solution to meet customer demand.
- Dispenses the right portion of liquid automatically
- 2 seconds interval between hand detection
- Made from 100% virgin material to ensure durability
- Soap level viewing window
- Key lock system to prevent pilferage
- 1 Liter capacity enable 2000 shots of liquid soap dispense

#### Packaging

Quantity : 12 units / Carton  
 Carton Size : 557(L) x 433(W) x 286(H)  
 CBM : 0.069 / carton  
 Gross Weight : ± 13.06 kgs

#### Specifications

Color Available : White  
 Material : ABS  
 Battery : 4 C size batteries (Heavy duty and above)  
 Capacity : 900ml (Refillable Container)  
 Capacity : 1000ml (Disposable Cartridge)  
 Product Dimensions : 113(L) x 122(W) x 260(H)  
 Type : Pump System  
 Dispensing Volume : 0.50ml per shot







AZ 1133

Refillable Container 900ml

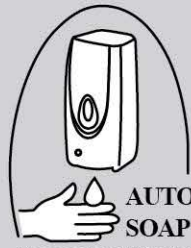
Disposable Cartridge 1000ml

#### Multiple Dispensing Systems

	<p><b>Model 1</b></p>  <p><b>AUTO SOAP</b> 2 second interval</p> <p>▲ AZ 1133-L8 Auto Liquid Soap Dispenser</p>	<p><b>Model 2</b></p>  <p><b>AUTO FOAM SOAP</b> 2 second interval</p> <p>▲ AZ 1133-F Foam Soap Dispenser</p>	<p><b>Model 3</b></p>  <p><b>AUTO HAND SANITIZER</b> 2 second interval</p> <p>▲ AZ 1133-L8 HS Auto Hand Sanitizer Dispenser</p>	<p><b>Model 4</b></p>  <p><b>TOILET SEAT CLEANER</b> 2 second interval</p> <p>▲ AZ 1133-M-TSC Toilet Seat Cleaner Dispenser</p>
--	--	---	--	---

#### Product Dimensions

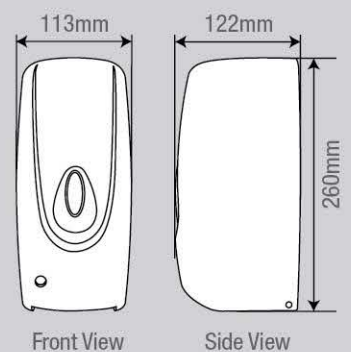





## Hand Soap Dispenser

### Hand washing

Promoting the hand hygiene practice to reduce the cross-contamination and prevent the spread of illness. Our range of hand soap dispensers with different type of dispensing system able to provide customer comprehensive hand hygiene solution and improving the hand hygiene level to users.

## AZ 1010 / 1010A Liquid Soap Dispenser (Horizontal Pump System)

### Product Info

- Clean, slim and compact design
- Equip with refillable container with lid
- Dispenser made from 100% virgin material to ensure durability
- Durable horizontal pump system can last up to 100k press
- Soap level viewing window
- Hidden keyless lock system

### Packaging

Quantity : 30 units / Carton  
 Carton Size : 540(L) x 440(W) x 500(H)  
 CBM : 0.120 / carton  
 Gross Weight : ± 17.27 kgs

### Specifications

Color Available : White  
 Material : ABS  
 Capacity : 1000ml  
 Product Dimensions : 125(L) x 95(W) x 222(H)  
 Type : Pump System  
 Dispensing Volume : 1.00ml per shot



### Colour Option

### Product Dimensions

AZ 1010



▲ White

125mm

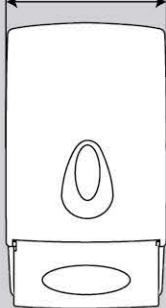

Front View

95mm

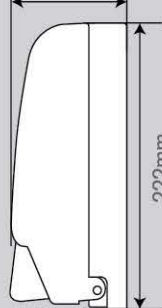

Side View

222mm

### Colour Option

### Product Dimensions

AZ 1010A



▲ White

125mm

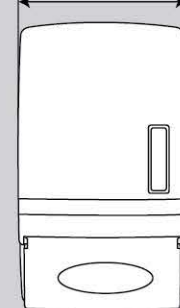

Front View

95mm

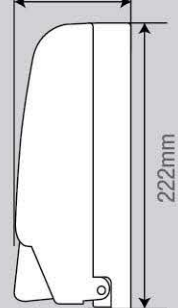

Side View

222mm





## Hand Soap Dispenser

### Hand washing

Promoting the hand hygiene practice to reduce the cross-contamination and prevent the spread of illness. Our range of hand soap dispensers with different type of dispensing system able to provide customer comprehensive hand hygiene solution and improving the hand hygiene level to users.

## AZ 1000 Liquid Soap Dispenser (Horizontal Pump System)

### Product Info

- Simple, slim and compact design
- Equip with refillable container with lid
- Dispenser made from 100% virgin material to ensure durability
- Durable horizontal pump system can last up to 100k press
- Soap level viewing window
- Hidden keyless lock system

### Packaging

Quantity : 30 units / Carton  
 Carton Size : 540(L) x 440(W) x 500(H)  
 CBM : 0.120 / carton  
 Gross Weight : ± 17.27 kgs

### Specifications

Color Available : White  
 Material : ABS  
 Capacity : 1000ml  
 Product Dimensions : 142(L) x 97(W) x 232(H)  
 Type : Pump System  
 Dispensing Volume : 1.00ml per shot



### Colour Option



▲ White

### Product Dimensions

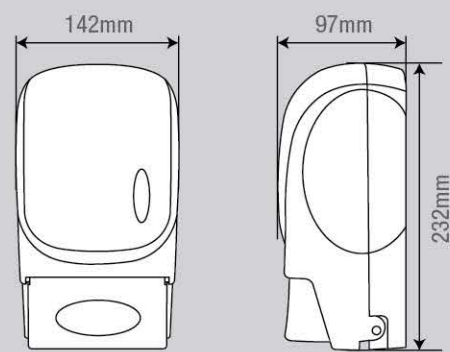

Front View

Side View





## Hand Soap Dispenser

### Hand washing

Promoting the hand hygiene practice to reduce the cross-contamination and prevent the spread of illness. Our range of hand soap dispensers with different type of dispensing system able to provide customer comprehensive hand hygiene solution and improving the hand hygiene level to users.

## Liquid Soap Dispensing Product (For Tube System)

### Product Info

- More hygiene hand washing experience without worry contamination from bulk refill
- Disposable cartridge with integrated dispensing tube
- User friendly and easy change over.
- Made from 100% virgin material to ensure durability

### Packaging

Quantity : 12 units / Carton  
 Carton Size : 342(L) x 288(W) x 143(H)  
 CBM : 0.014 / carton  
 Gross Weight : ± 9.13 kgs

### Fragrance

- Sky Blue (Transparent White)
- Lemon (Yellow)
- Green (Apple Blossom)
- Red (Strawberry)
- Pink (Floral)
- Others

### Specifications

Color Available : Disposable cartridge white box  
 Capacity : 600ml / 700ml  
 Product Dimensions : 108(L) x 67(W) x 132(H)  
 Dispensing Volume : 0.40ml per shot

### Liquid Soap Dispensing Product



### Product Dimensions

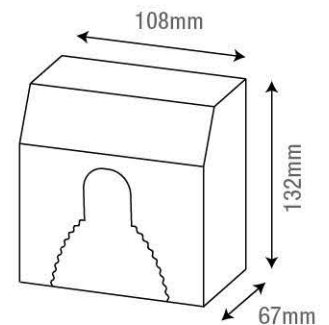

## Foam Soap Dispensing Product (For Vertical Pump System)

### Foam Soap Dispensing Product



### Product Dimensions

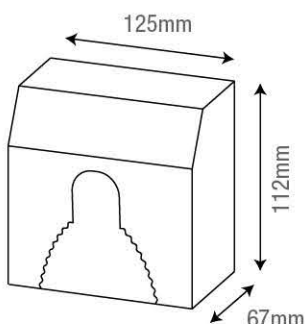

### Product Info

- More hygiene hand washing experience without worry contamination from bulk refill
- Disposable cartridge with integrated dispensing tube
- User friendly and easy change over.
- Made from 100% virgin material to ensure durability

### Packaging

Quantity : 12 units / Carton  
 Carton Size : 335(L) x 280(W) x 125(H)  
 CBM : 0.014 / carton  
 Gross Weight : ± 8.10 kgs

### Fragrance

- Green (Apple Blossom)
- Others

### Specifications

Color Available : Disposable cartridge white box  
 Capacity : 600ml / 650ml  
 Product Dimensions : 125(L) x 67(W) x 112(H)  
 Dispensing Volume : 0.40ml per shot





## Tissue & Paper Tower Dispenser



Using paper in our daily cleaning and drying become essential and common now a day

Customers are more focus on the convenience and effectiveness when choosing a paper product. Our wide range of paper dispenser consists of toilet paper dispenser, pop-up tissue dispenser, hand towel dispenser and center pull tissue dispenser able to fit most of the market tissue and durability ensured.

### AR 1008 Jumbo Roll Tissue Dispenser

#### Product Info

- Stylist and contemporary design
- Operation friendly key lock system
- Tissue level viewing window
- Multiple wall mounting screw position to ensure flexible mounting position
- Suitable to use with tissue without perforation line with strong and safe cutting teeth
- Optional for big or small inner core to suit different country standard
- All part made from 100% virgin material to ensure durability
- Optional transparent cover for easy tissue consumable level check
- Multiple choice of material and color to suit different needs

#### Packaging

Quantity : 6 units / Carton  
 Carton Size : 538(L) x 408(W) x 292(H)  
 CBM : 0.064 / carton  
 Gross Weight : ± 4.564 kgs

#### Specifications

Colour Available : White / Transparent Dark Blue  
 Maximum tissue size : 230 Diameter  
 Material : ABS  
 Product Dimensions : 258(L) x 127.5(W) x 279(H)  
 Core Size Options : 35mm / 70mm (Diameter)



#### Colour Option



▲ White

▲ Transparent Dark Blue

▲ Internal Structure

#### Product Dimensions

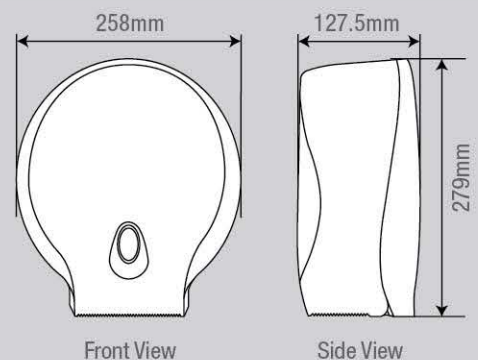

Front View

Side View





## Tissue & Paper Tower Dispenser



Using paper in our daily cleaning and drying become essential and common now a day

Customers are more focus on the convenience and effectiveness when choosing a paper product. Our wide range of paper dispenser consists of toilet paper dispenser, pop-up tissue dispenser, hand towel dispenser and center pull tissue dispenser able to fit most of the market tissue and durability ensured.

### AZ 1008 Jumbo Roll Tissue Dispenser

#### Product Info

- Simple and stylist design
- Operation friendly key lock system
- Tissue level viewing window
- Multiple wall mounting screw position to ensure flexible mounting position
- Suitable to use with tissue without perforation line with strong and safe cutting teeth
- Optional for big or small inner core to suit different country standard
- All part made from 100% virgin material to ensure durability
- Optional transparent cover for easy tissue consumable level check
- Multiple choice of material and color to suit different needs

#### Packaging

Quantity : 6 units / Carton  
 Carton Size : 585(L) x 387(W) x 320(H)  
 CBM : 0.072 / carton  
 Gross Weight : ± 5.20 kgs

#### Specifications

Colour Available : White / Transparent Light Grey / Transparent Black  
 Maximum tissue size : 270mm  
 Material Options : ABS / AS  
 Product Dimensions : 280(L) x 122(W) x 298(H)  
 Core Size Options : 35mm / 70mm (Diameter)

AZ 1008



#### Colour Option



▲ White    ▲ Transparent Light Grey    ▲ Transparent Black    ▲ Internal Structure

#### Product Dimensions

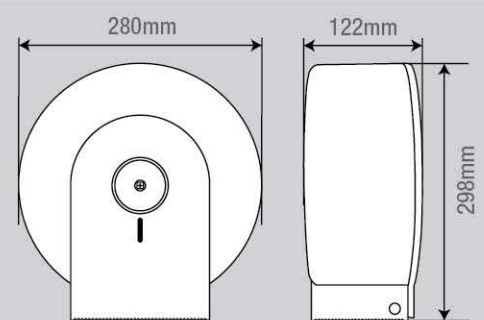

Front View

Side View





## Tissue & Paper Tower Dispenser



Using paper in our daily cleaning and drying become essential and common now a day

Customers are more focus on the convenience and effectiveness when choosing a paper product. Our wide range of paper dispenser consists of toilet paper dispenser, pop-up tissue dispenser, hand towel dispenser and center pull tissue dispenser able to fit most of the market tissue and durability ensured.

### AZ 1123 Multi-Fold Tissue Dispenser

#### Product Info

- Stylist, slim and compact design
- Operation friendly key lock system
- Tissue level viewing window
- Multiple wall mounting screw position to ensure flexible mounting position
- Able to suit the multiple types of tissue paper (M-fold, C-Fold, V-Fold, Z-fold and interfold)
- Able to fit 2-3 packs of tissue paper (Depending on tissue standard)
- All part made from 100% virgin material to ensure durability
- Optional transparent cover for easy tissue consumable level check
- Multiple choice of material and color to suit different needs and preference

#### Packaging

Quantity : 6 units / Carton  
 Carton Size : 582(L) x 405(W) x 403(H)  
 CBM : 0.095 / carton  
 Gross Weight : ± 7.54 kgs

#### Specifications

Colour Available : White / Transparent Blue  
 Maximum tissue size : 250(L) x 90(W)  
 Material : ABS  
 Product Dimensions : 275(L) x 118(W) x 372(H)

AZ 1123



#### Colour Option



▲ White



▲ Transparent Blue



▲ Internal Structure

#### Product Dimensions

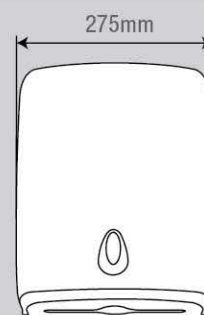

Front View

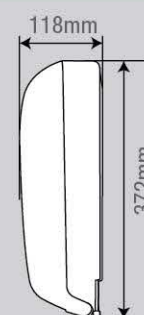

Side View





## Tissue & Paper Tower Dispenser



### Using paper in our daily cleaning and drying become essential and common now a day

Customers are more focus on the convenience and effectiveness when choosing a paper product. Our wide range of paper dispenser consists of toilet paper dispenser, pop-up tissue dispenser, hand towel dispenser and center pull tissue dispenser able to fit most of the market tissue and durability ensured.

### AZ 1220 Multi-Fold Tissue Dispenser

#### Product Info

- Stylist, slim and compact design
- Key lock system to prevent pilferage
- Tissue level viewing window
- Multiple wall mounting screw position to ensure flexible mounting position
- Able to suit the multiple types of tissue paper (M-fold, C-Fold, V-Fold, Z-fold and interfold)
- Able to fit 1 to 2 packs of tissue paper (Depending on tissue standard)
- All part made from 100% virgin material to ensure durability

#### Packaging

Quantity : 6 units / Carton  
 Carton Size : 815(L) x 268(W) x 273(H)  
 CBM : 0.060 / carton  
 Gross Weight : ± 5.038 kgs

#### Specifications

Colour Available : White  
 Maximum tissue size : 240(L) x 100(W)  
 Material : ABS  
 Product Dimensions : 254(L) x 118(W) x 256(H)



#### Product Dimensions



▲ White



▲ Internal Structure

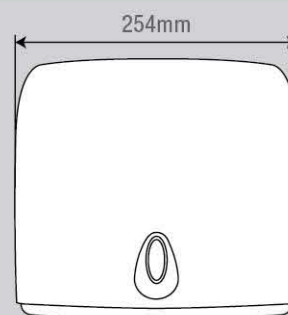

Front View

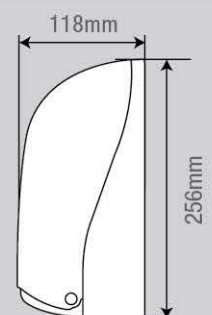

Side View





## Tissue & Paper Tower Dispenser



Using paper in our daily cleaning and drying become essential and common now a day

Customers are more focus on the convenience and effectiveness when choosing a paper product. Our wide range of paper dispenser consists of toilet paper dispenser, pop-up tissue dispenser, hand towel dispenser and center pull tissue dispenser able to fit most of the market tissue and durability ensured.

### AZ 1221 Multi-Fold Tissue Dispenser

#### Product Info

- Simple and compact design
- Top button opening
- Able to fit 1 to 2 packs of tissue paper (Depending on tissue standard)
- Multiple wall mounting screw position to ensure flexible mounting position
- Able to suit the multiple types of tissue paper (M-fold, C-Fold, V-Fold, Z-fold and interfold)
- Optional transparent cover to easy tissue consumable level check
- All part made from 100% virgin material to ensure durability

#### Packaging

Quantity : 12 units / Carton  
 Carton Size : 511(L) x 344(W) x 365(H)  
 CBM : 0.064 / carton  
 Gross Weight : ± 6.60 kgs

#### Specifications

Colour Available : White / Transparent Blue  
 Maximum tissue size : 230(L) x 95(W)  
 Material : ABS  
 Product Dimensions : 252(L) x 106(W) x 168(H)



#### Product Dimensions



◀ Internal Structure

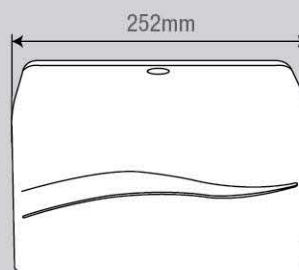

Front View

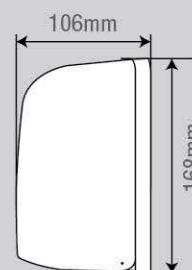

Side View





## Tissue & Paper Tower Dispenser



Using paper in our daily cleaning and drying become essential and common now a day

Customers are more focus on the convenience and effectiveness when choosing a paper product. Our wide range of paper dispenser consists of toilet paper dispenser, pop-up tissue dispenser, hand towel dispenser and center pull tissue dispenser able to fit most of the market tissue and durability ensured.

### AZC 003 Multi-Fold Tissue Dispenser

#### Product Info

- Simple and compact design
- Top button opening
- Able to fit 1 to 2 packs of tissue paper (Depending on tissue standard)
- Multiple wall mounting screw position to ensure flexible mounting position
- Able to suit the multiple types of tissue paper (M-fold, C-Fold, V-Fold, Z-fold and interfold)
- Optional transparent cover to easy tissue consumable level check
- All part made from 100% virgin material to ensure durability

#### Packaging

Quantity : 12 units / Carton  
 Carton Size : 511(L) x 344(W) x 365(H)  
 CBM : 0.064 / carton  
 Gross Weight : ± 6.60 kgs

#### Specifications

Colour Available : White / Transparent Blue  
 Maximum tissue size : 230(L) x 95(W)  
 Material : ABS  
 Product Dimensions : 247(L) x 106(W) x 168(H)



#### Product Dimensions



◀ Internal Structure

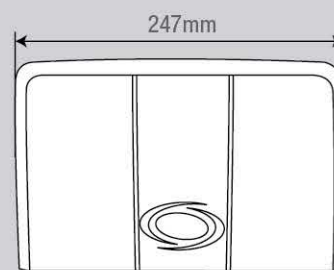

Front View

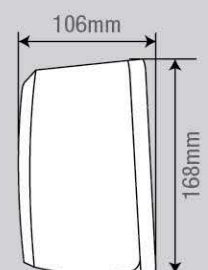

Side View





## Tissue & Paper Tower Dispenser



Using paper in our daily cleaning and drying become essential and common now a day

Customers are more focus on the convenience and effectiveness when choosing a paper product. Our wide range of paper dispenser consists of toilet paper dispenser, pop-up tissue dispenser, hand towel dispenser and center pull tissue dispenser able to fit most of the market tissue and durability ensured.

### AZ 1009 Hygiene Bath Room Tissue Dispenser

#### Product Info

- Simple and compact design
- Dual option key lock system. Top button opening or key poke system.
- Able to fit 2-3 pack of tissue paper (Depending on tissue standard)
- Multiple wall mounting screw position to ensure flexible mounting position
- Optional transparent cover to easy tissue consumable level check
- All part made from 100% virgin material to ensure durability

#### Packaging

Quantity : 12 units / Carton  
 Carton Size : 537(L) x 457(W) x 303(H)  
 CBM : 0.074 / carton  
 Gross Weight : ± 9.20 kgs

#### Specifications

Colour Available : White / Transparent Black  
 Maximum tissue size : 125(L) x 120(W)  
 Material : ABS  
 Product Dimensions : 135(L) x 123(W) x 274(H)

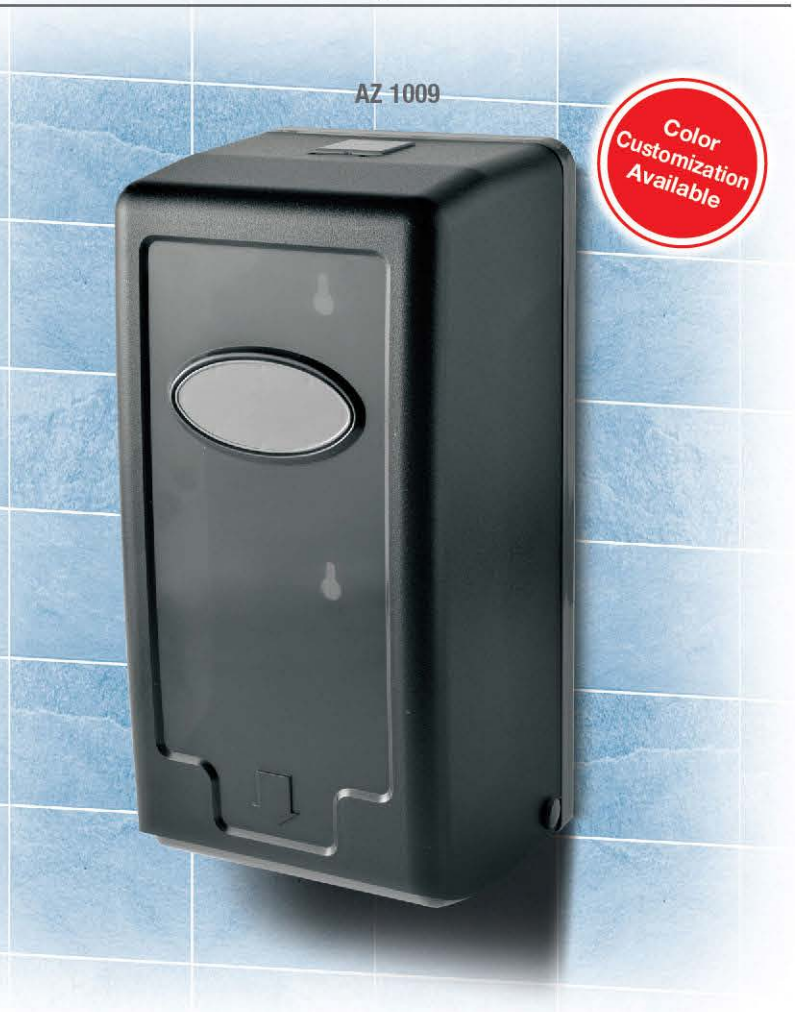

#### Colour Option



▲ Transparent Black



▲ White



▲ Internal Structure

#### Product Dimensions

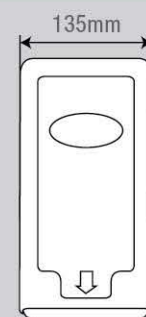

Front View

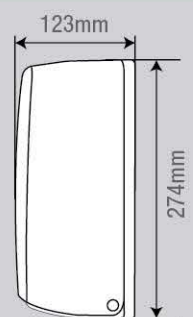

Side View





# Tissue & Paper Tower Dispenser



Using paper in our daily cleaning and drying become essential and common now a day

Customers are more focus on the convenience and effectiveness when choosing a paper product. Our wide range of paper dispenser consists of toilet paper dispenser, pop-up tissue dispenser, hand towel dispenser and center pull tissue dispenser able to fit most of the market tissue and durability ensured.

## AZC 009 Pop Up Tissue Dispenser

### Product Info

- Stylish and compact design.
- Economical use and ease of use
- Able to fit 1 to 2 packs of tissue paper (Depending on tissue standard)
- Easily accessible to tissue paper
- Able to put toothpick and slot in for menu
- Suitable use for restaurant
- 100% virgin material to ensure durability

Internal Structure ▶



### Specifications

Colour Available : White  
 Maximum tissue size : 110(L) x 105(W)  
 Material : ABS  
 Product Dimensions : 113(L) x 108(W) x 159(H)

### Packaging

Quantity : 24 units / Carton  
 Carton Size : 677(L) x 238(W) x 344(H)  
 CBM : 0.055 / carton  
 Gross Weight : ± 6.97 kgs

## AZ 1101 Pop Up Tissue Dispenser

### Product Info AZ

- Economical use and ease of use
- Able to fit 1 pack of tissue paper
- Easily accessible to tissue paper
- Suitable use for restaurant
- Made from 100% virgin material

Internal Structure ▶



### Specifications

Colour Available : Red / Yellow  
 Maximum tissue size : 115(L) x 115(W)  
 Material : PP  
 Product Dimensions : 115(L) x 115(W) x 77(H)

### Packaging

Quantity : 120 units / Carton  
 Carton Size : 588(L) x 470(W) x 445(H)  
 CBM : 0.123 / carton  
 Gross Weight : ± 8.88 kgs

### Colour Option



▲ Yellow

▲ Red

### Product Dimensions

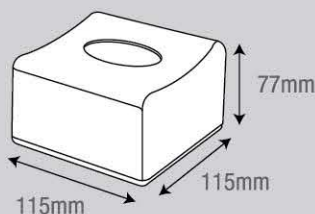

### Product Dimensions

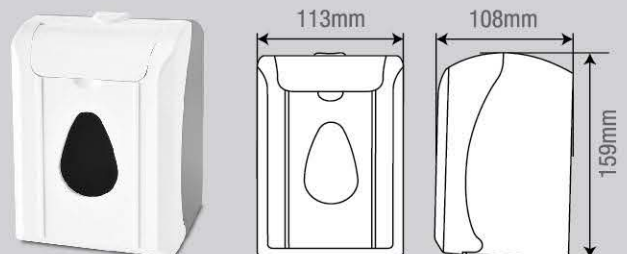

▲ White

Front View

Side View





## Tissue & Paper Tower Dispenser



Using paper in our daily cleaning and drying become essential and common now a day

Customers are more focus on the convenience and effectiveness when choosing a paper product. Our wide range of paper dispenser consists of toilet paper dispenser, pop-up tissue dispenser, hand towel dispenser and center pull tissue dispenser able to fit most of the market tissue and durability ensured.

### AZ 1300 / 1300 A / 1300 M / 1300 M (A) Center Pull Tissue Dispenser

#### Product Info AZ 1300 / 1300 M

- Free Flow tissue cutter funnel.
- Dispense tissue amount as per personal preference usage
- Suitable to use with tissue without perforation line with strong and safe cutting teeth
- Equips with wall mounting plate to easy the dispenser installation and removal.
- User friendly slot in and out installation mechanism
- Optional transparent cover for easy content viewing
- Multiple choice of material and color to suit different needs
- Able to suit most of the market tissue size

#### Product Info AZ 1300 A / 1300 M (A)

- Adjustable Auto-cut funnel.
- To use with maxi-roll tissue with perforation line.
- Use adjustable auto-cut funnel to minimize unnecessary tissue wastage
- Equips with wall mounting plate to easy the dispenser installation and removal.
- User friendly slot in and out installation mechanism
- Optional transparent cover for easy content viewing
- Multiple choice of material and color to suit different needs
- Able to suit most of the market tissue size



AZ 1300  
(Free Flow Funnel)



AZ 1300 M  
(Free Flow Funnel)



AZ 1300 A  
(Auto Cut Funnel)



AZ 1300 M (A)  
(Auto Cut Funnel)

#### Specifications AZ 1300 / 1300 A

Maximum tissue size : 240 diameter x 170(H)  
Material : ABS / AS  
Product Dimensions : 250 Diameter x 315 (H)

#### Packaging AZ 1300 / 1300 A

Quantity : 6 units / Carton  
Carton Size : 783(L) x 592(W) x 304(H)  
CBM : 0.14 / carton  
Gross Weight : ± 9.90 kgs

#### Specifications AZ 1300 M / 1300 M (A)

Maximum tissue size : 215 diameter x 155(H)  
Material : ABS / AS  
Product Dimensions : 226 Diameter x 290 (H)

#### Packaging AZ 1300 M / 1300 M (A)

Quantity : 6 units / Carton  
Carton Size : 730(L) x 535(W) x 276(H)  
CBM : 0.108 / carton  
Gross Weight : ± 7.78 kgs

### Product Dimensions



▲ Internal Structure

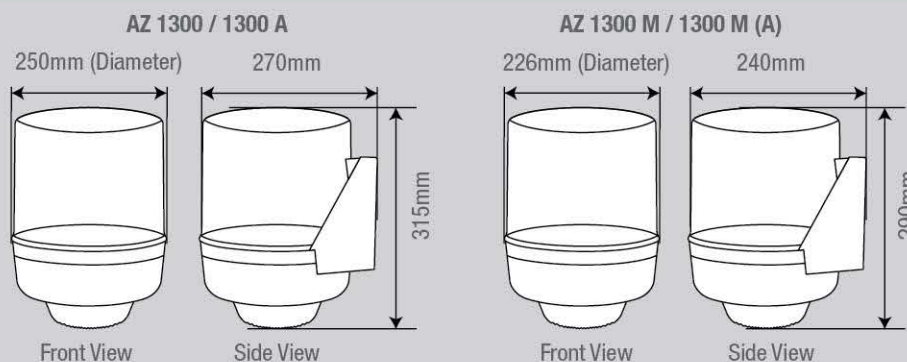





## Urinal Hygiene

### Provide a clean, hygienic and odour free washroom environment

The unpleasant odors are always associated with poor hygiene washroom. Our urinal hygiene products clean, deodorizes and disinfects the urinals, thereby provide a clean, hygienic and odour-free washroom environment to all users.

### AZS 012 / 013 Urinal Sanitizer Dispenser

#### Product Info AZS 012 Urinal Sanitizer Dispenser

- Streamline and compact design
- Adjustable continuous dripping rate to suit different usage traffic
- Flexible hose to ease installation in different urinal bowl design
- Optional install over toilet bowls or urinal bowl
- Clean and disinfect the urinal and toilet bowls
- Deodorizer provides odourless environment and pleasant fragrance
- Prevent bacterial growth and reduce stains
- Refillable container to reduce cost
- 600ml capacity enable to last over 30 days of drip fluid
- Made from 100% virgin and chemicals resistance material
- Operation friendly key lock system to prevent pilferage

#### Product Info AZS 013 Urinal Sanitizer Dispenser

- Streamline and compact design
- Demand flush system, disinfectant in each flush. Save cost and reduce wastage.
- Optional install over toilet bowls or urinal bowl
- Clean and disinfect the urinal and toilet bowls with each flush
- Deodorizer provides odourless environment and pleasant fragrance
- Anti- bacterial growth and reduce stains
- Refillable container to reduce cost
- 600ml capacity enable to last over 30 days of flush fluid
- Made from 100% virgin and chemicals resistance material
- Operation friendly key lock system to prevent pilferage



#### Packaging

Quantity : 30 units / Carton  
 Carton Size : 648(L) x 536(W) x 243(H)  
 CBM : 0.084 / carton  
 Gross Weight : ± 12.0 kgs

#### Specifications

Colour Available : White  
 Material : PP  
 Capacity : 600ml  
 Product Dimensions : 124(L) x 81(W) x 204(H)

AZS 012 (Dripping)



▲ White

AZS 013 (Flushing)



▲ White

#### Product Dimensions

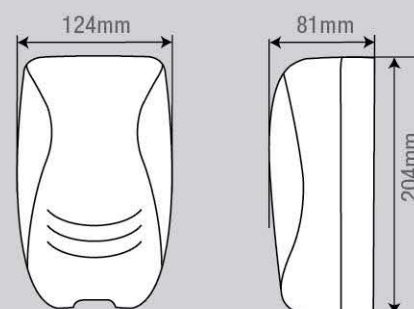

Front View

Side View





## Urinal Hygiene

### Provide a clean, hygienic and odour free washroom environment

The unpleasant odors are always associated with poor hygiene washroom. Our urinal hygiene products clean, deodorizes and disinfects the urinals, thereby provide a clean, hygienic and odour-free washroom environment to all users.

### AZ 360 / 361 Urinal Screen

#### Product Info AZ 360 Urinal Screen

- Flexible design enable easy fit into urinals
- Up to 30 days usage life
- Water and heat activated fragrance delivery system
- When not in use, the product delivers minimum fragrance.
- It activated when flushing with water or urine on the urinal screen.
- Added anti-bacterial active ingredient.
- Anti-splashing spike design to prevent urine splash back and maintain cleaner floor.
- Anti slip design to keep the urinal screen in optimum position
- Prevent trash such as cigarette butt clog the drainage system

#### Product Info AZ 361 Urinal Screen

- Flexible design enable easy fit into urinals
- Min 30 days usage life
- Double fragrance coverage area compared to AZ 360
- Water and heat activated fragrance delivery system
- When not in use, the product delivers minimum fragrance.
- It activated when flushing with water or urine on the urinal screen.
- Added anti-bacterial active ingredient.
- Extra long anti-splashing spike design to prevent urine splash back and maintain cleaner floor.
- Anti slip design to keep the urinal screen in optimum position
- Prevent trash such as cigarette butt clog the drainage system

#### Packaging AZ 360 Urinal Screen

Quantity : 144 pcs / Carton  
 Carton Size : 490(L) x 392(W) x 197(H)  
 CBM : 0.038 / carton  
 Gross Weight : ± 6.20 kgs

#### Specifications AZ 360 Urinal Screen

Colour Available : • Tropical Fruits (Orange)  
 • Cool Lemonade (Yellow) • Orchard Blush (Green)  
 • Cherry Delight (Pink) • Lavender (Purple)  
 • Tropical Mango • Pee Wee (Blue)  
 • Sherwin (Red)  
 Product Dimensions : 150mm (Diameter)

AZ 360 Urinal Screen

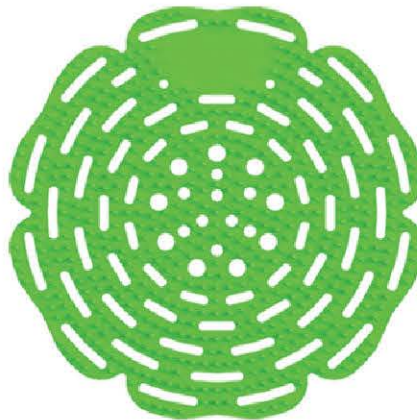

AZ 361 Urinal Screen

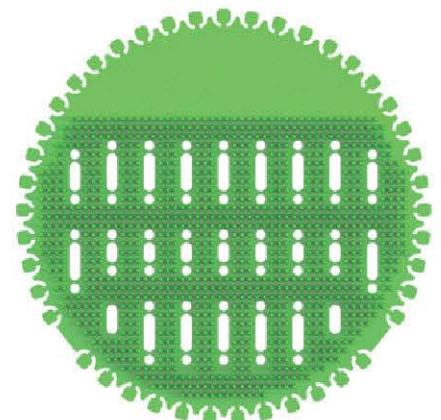

#### Packaging AZ 361 Urinal Screen

Quantity : 72 pcs / Carton  
 Carton Size : 555(L) x 420(W) x 155(H)  
 CBM : 0.036 / carton  
 Gross Weight : ± 5.5 kgs

#### Specifications AZ 361 Urinal Screen

Colour Available : • Tropical Fruits (Orange)  
 • Cool Lemonade (Yellow) • Orchard Blush (Green)  
 • Cherry Delight (Pink) • Lavender (Purple)  
 • Tropical Mango • Pee Wee (Blue)  
 • Sherwin (Red)  
 Product Dimensions : 165mm (Diameter)

#### Colour Option

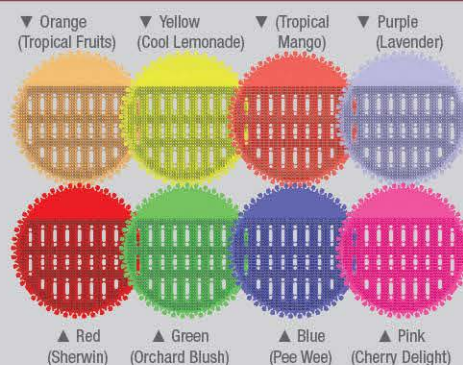
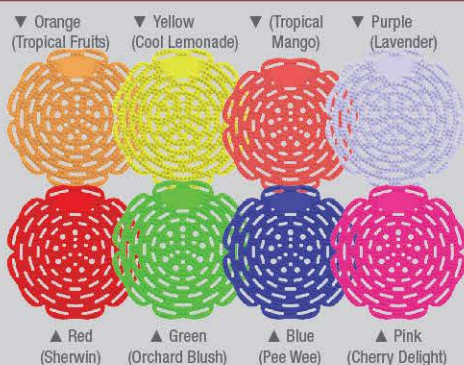

#### Product Dimensions

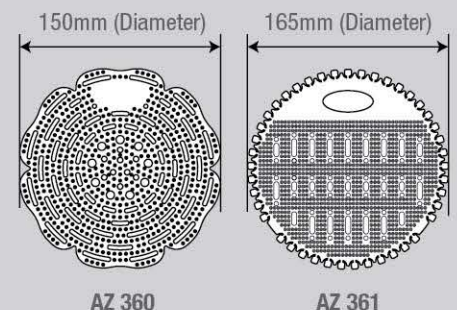





## Urinal Hygiene

### Provide a clean, hygienic and odour free washroom environment

The unpleasant odors are always associated with poor hygiene washroom. Our urinal hygiene products clean, deodorizes and disinfects the urinals, thereby provide a clean, hygienic and odour-free washroom environment to all users.

### AZ 1011 Para Deodorant Block (20kg Drum)

#### Product Info

- Air-activated
- Clean and deodorizes the unpleasant odours

#### Packaging

Quantity : 1 Drum  
Gross Weight : ± 21.279 kgs

#### Specifications

Product Dimensions : 360 (Diameter) x 260(H)

AZ 1011 (20kg Drum)



#### Product Dimensions

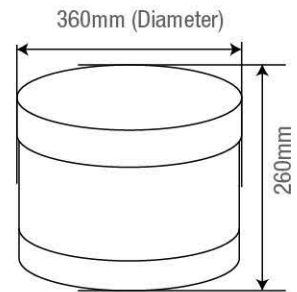

### AZ 1011 Para Deodorant Block (5kg Steel Tin)

#### Product Info

- Air-activated
- Clean and deodorizes the unpleasant odours

#### Packaging

Quantity : 1 Tin  
Gross weight : 5.0 kgs

#### Specifications

Product Dimensions : 180 (Diameter) x 285(H)

AZ 1011 (5kg Steel Tin)



#### Product Dimensions

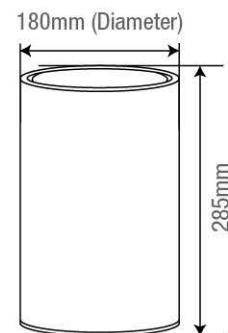

### AZ 1011 Para Deodorant Block (3/5kg Plastic Drum)

#### Product Info

- Air-activated
- Clean and deodorizes the unpleasant odours

#### Packaging

Quantity : 2 pails / carton  
Carton size : 495(L) x 257(W) x 201(H)  
CBM : 0.026  
Gross weight : 4.3 kgs (3kg Plastic Drum)  
Gross weight : 6.3 kgs (5kg Plastic Drum)

#### Specifications

Product Dimensions : 240 (Diameter) x 195(H)

AZ 1011 (3/5kg Plastic Drum)



#### Product Dimensions







## Urinal Hygiene

### Provide a clean, hygienic and odour free washroom environment

The unpleasant odors are always associated with poor hygiene washroom. Our urinal hygiene products clean, deodorizes and disinfects the urinals, thereby provide a clean, hygienic and odour-free washroom environment to all users.

### AZ 1106 Para Deodorant Triangle Block (90gm)

#### Product Info

- Triangle-shaped
- Generally lasting (Para Base) between 14 days to 21 days (depend on usage frequency)
- Generally lasting (Enzyme Base) for a minimum of 30 to 45 days (depend on usage frequency)
- Economical long term odour control for urinals
- Suitable for low-flushing, waterless urinal system
- Deodorizer to eliminate the urine odour and delivers pleasant fragrance.

#### Product Dimensions

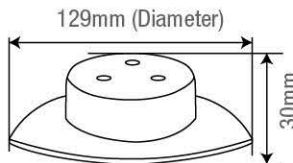

#### Packaging

Quantity : 100 units / Carton  
 Carton Size : 510(L) x 320(W) x 285(H)  
 CBM : 0.047 / carton  
 Gross Weight : ± 12.14 kgs

#### Specifications

Colour Available : Yellow, Blue, Pink  
 Product Dimensions : 129 (Diameter) x 30(H)



### AZ 1125 Enzyme Base Bio Tab (50gm)

#### Product Info

- Round-shaped, pleasant to use
- Biodegradable and does not contain paradichlorobenzene (carcinogenic chemical)
- Environmentally to use – made by enzyme, non-toxic, non corrosive ingredients is harmless to environment, drain pipes
- Economical to use- slowly dissolve when in use
- Generally lasting for a minimum of 30 to 60 days (depend on usage frequency)
- Economical long term odour control for urinals
- Deodorizer with enzyme to eliminate the urine odour and delivers pleasant fragrance.

#### Packaging

Quantity : 72 units / Carton  
 Carton Size : 484(L) x 366(W) x 242(H)  
 CBM : 0.043 / carton  
 Gross Weight : ± 7.03 kgs

#### Specifications

Colour Available : Pink, Blue  
 Product Dimensions : 115 (Diameter) x 35(H)



### Auto Toilet Flush Disinfectant (100gm)

#### Product Info

- Able to flush up to 600 times
- Formulated to clean toilet bowl thoroughly
- Clean, deodorizes, freshener the toilet bowl with each flush
- Automatically emit fragrance and blue disinfectant into the system and ready for next flush

#### Packaging

Quantity : 30 units / Carton  
 Carton Size : 371(L) x 219(W) x 158(H)  
 CBM : 0.013 / carton  
 Gross Weight : ± 4.50 kgs

#### Specifications

Colour Available : Blue  
 Material : ABS  
 Product Dimensions : 65 (Diameter) x 73(H)

#### Product Dimensions



Auto Toilet Flush Disinfectant







## Hand Dryer

### Provide a quick hand drying solution

Automatic hand dryer is an effective and quick hand drying solution and eliminates the needs of paper towel for hand drying purpose. This is the right choice if you are looking for an eco-friendly and cost saving solution in hand drying.

### AZ 1035 Automatic Hand Dryer

#### Product Info

- Stylist and compact design
- Reduce wastage of tissue paper
- Relieving the daily replenishment of paper towels and paper waste disposal
- Touch free operation for cross-contamination free and increased hygiene
- Hand drying in 30-45 seconds
- Smart sensor activated system

#### Packaging

Quantity : 6 units / Carton  
 Carton Size : 710(L) x 338(W) x 390(H)  
 CBM : 0.094 / carton  
 Gross Weight : ± 13.1 kgs

#### Specifications

Colour Available : White  
 Material : ABS  
 Voltage : 240V~/ 50Hz  
 Rated Power : 1000W  
 Rate Current : 4.2A  
 Water Splash Proof : IPX1  
 Blowing Volume : 51m<sup>3</sup>/h  
 Air Speed : 9.8M/S  
 Shock Guard :   
 Product Dimensions : 210(L) x 135(W) x 285(H)



#### Product Dimensions



▲ White

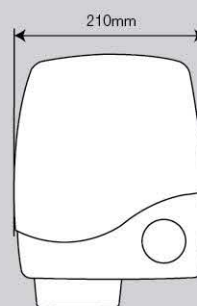

Front View

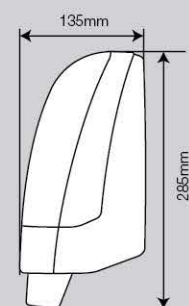

Side View





## Feminine Hygiene

### Provides a hygienic and convenient solution of sanitary disposal in the female washroom

Sanitary bin is an important consideration to be provided in female washroom. Our sanitary bin is able to provide hygienic and convenient way of sanitary disposal in the female washroom, make the female visitors and employees feel more comfortable and reassure.

### AZ 1800 Lady Sanitary Bin

#### Product Info

- Dual operation mode.
- Hand Free stepping pedal and knob on lid for customer prefers hand operation.
- Ergonomic design with hand level disposal height in sitting position.
- Dual purpose V-shape lid design. To minimize back flow of bad odor when lid open and block the visual of bin content.
- Wide foot pedal for easy stepping.
- Chemicals resistance material. Worry free with any cleaning and sanitation chemicals.
- All part made from 100% virgin material to ensure durability.

#### Specifications

- Colour Available : White, Grey and Blue
- Material : ABS
- Capacity : 18 Liter
- Material : ABS
- Product Dimensions : 185(L) x 330(W) x 608(H)

AZ 1800



#### Packing 1/3 : Bin

- Packaging : 15 units / bundle
- Product size : 179(L) x 326(W) x 560(H)
- Gross weight : 22.05kgs
- Material : Poly Propylene

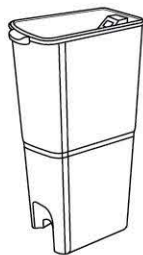

#### Packing 3/3 : Long & Short Pedal

- Packaging : 12 sets / carton
- Carton size : 545(L) x 178(W) x 150(H)
- CBM : 0.015
- Gross weight : 2.54kgs
- Material : Poly Propylene

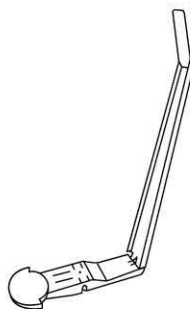

#### Packing 2/3 : Cover and Lid

- Packaging : 12 sets / carton
- Carton size : 610(L) x 335(W) x 380(H)
- CBM : 0.078
- Gross weight : 4.91kgs
- Material : Poly Propylene



#### Colour Option



▲ White



▲ Grey



▲ Blue

#### Product Dimensions

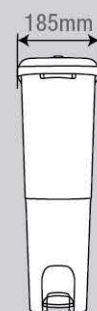

Front View



Side View





## Mopping Bucket

IN PROGRESS

### Provide a fresh environment

Mopping bucket is an essential cleaning equipment to clean the floor, especially for the commercial use. Always keep the floor clean able to leave the good impression and enhance the company's image. Our mopping bucket feature ergonomic design that suit most of operator height and high efficiency down press wringer, which enable the user convenient to use and for their well-being.

### AZ 1032 Down Press Wringer Bucket (22 Liter)

#### Product Info

- Down press mechanism for better mop drying and operation.
- Engineering plastic gearing system and water press to ensure high friction and strength
- Roller with protective bumper to avoid bucket collide with surrounding
- Equips with mop clip to hold mop stick when moving the trolley
- Easy and smooth turning roller to ease the bucket mobility
- Equips with handle as alternative carry method in some circumstances such as staircase
- Ergonomic design to suit most of the operator height
- All part made from 100% virgin material to ensure durability
- Able to use with most of the available mop
- Wringer alone able to fit most of the bucket in the market and available to sell separately.

#### Packaging

Quantity : 1 unit / Carton  
 Carton Size : 403(L) x 318(W) x 417(H)  
 CBM : 0.054 / carton  
 Gross Weight : ± 4.95 kgs

#### Specifications

Colour Available : Yellow, Green, Red and Blue  
 Material : PP  
 Capacity : 22 Liter  
 Product Dimensions : 312(L) x 396(W) x 750(H)

#### Related

Kindly refer to page 43 - 46 for related product options



AZ 1032



#### Colour Option



▲ Yellow

▲ Green

▲ Red

▲ Blue

#### Product Dimensions







## Mopping Bucket

IN PROGRESS

### Provide a fresh environment

Mopping bucket is an essential cleaning equipment to clean the floor, especially for the commercial use. Always keep the floor clean able to leave the good impression and enhance the company's image. Our mopping bucket feature ergonomic design that suit most of operator height and high efficiency down press wringer, which enable the user convenient to use and for their well-being.

### AZ 1032W Down Press Wringer

#### Product Info

- Down press mechanism for better mop drying and operation.
- Engineering plastic gearing system and water press to ensure high friction and strength
- Equips with mop clip to hold mop stick when moving the trolley
- All part made from 100% virgin material to ensure durability

#### Packaging

Quantity : 2 units / Carton  
 Carton Size : 460(L) x 250(W) x 357(H)  
 CBM : 0.041 / carton  
 Gross Weight : ± 4.87 kgs

#### Specifications

Colour Available : Yellow, Green, Red and Blue  
 Material : PP  
 Product Dimensions : 249(L) x 385(W) x 510(H)

#### Related

Kindly refer to page 43 - 46 for related product options



AZ 1032W



#### Colour Option



▲ Yellow

▲ Green

▲ Red

▲ Blue

#### Product Dimensions

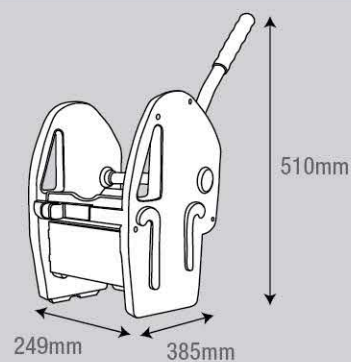





## Mopping Bucket

IN PROGRESS

### Provide a fresh environment

Mopping bucket is an essential cleaning equipment to clean the floor, especially for the commercial use. Always keep the floor clean able to leave the good impression and enhance the company's image. Our mopping bucket feature ergonomic design that suit most of operator height and high efficiency down press wringer, which enable the user convenient to use and for their well-being.

### AZ 1036 Down Press Wringer Double Bucket (23 + 23 Liter)

#### Product Info

- Metal handle trolley equipped with two buckets for rinsing and cleaning purposes
- Down press mechanism for better mop drying and operation.
- Engineering plastic gearing system and water press to ensure high friction and strength
- Roller with protective bumper to avoid bucket collide with surrounding
- Equips with mop clip to hold mop stick when moving the trolley
- Easy and smooth turning roller to ease the bucket mobility
- Ergonomic design to suit most of the operator height
- All part made from 100% virgin material to ensure durability
- Able to use with most of the available mop
- Wringer and bucket easily removable
- Wringer alone able to fit most of the bucket in the market and available to sell separately.

#### Packaging

Quantity : 1 unit / Carton  
 Carton Size : 725(L) x 430(W) x 398(H)  
 CBM : 0.124 / carton  
 Gross Weight : ± 10.18 kgs

#### Specifications

CColour Available : Green  
 Material : PP  
 Capacity : 23 + 23 Liter  
 Product Dimensions : 450(L) x 790(W) x 865(H)

#### Related

Kindly refer to page 43 - 46 for related product options



AZ 1036



#### Colour Option



▲ Green

#### Product Dimensions







## Mopping Bucket

IN PROGRESS

### Provide a fresh environment

Mopping bucket is an essential cleaning equipment to clean the floor, especially for the commercial use. Always keep the floor clean able to leave the good impression and enhance the company's image. Our mopping bucket feature ergonomic design that suit most of operator height and high efficiency down press wringer, which enable the user convenient to use and for their well-being.

### AZ 1033 Down Press Wringer Bucket (28 Liter)

#### Product Info

- Down press mechanism for better mop drying and operation.
- Engineering plastic gearing system and water press to ensure high friction and strength
- Roller with protective bumper to avoid bucket collide with surrounding
- Equips with mop clip to hold mop stick when moving the trolley
- Easy and smooth turning roller to ease the bucket mobility
- Equips with handle as alternative carry method in some circumstances such as staircase
- Ergonomic design to suit most of the operator height
- All part made from 100% virgin material to ensure durability
- Able to use with most of the available mop
- Wringer alone able to fit most of the bucket in the market and available to sell separately.

#### Packaging

Quantity : 1 unit / Carton  
 Carton Size : 447(L) x 372(W) x 410(H)  
 CBM : 0.068 / carton  
 Gross Weight : ± 6.22 kgs

#### Specifications

Colour Available : Yellow, Blue  
 Material : PP  
 Capacity : 28 Liter  
 Product Dimensions : 370(L) x 505(W) x 790(H)

#### Related

Kindly refer to page 43 - 46 for related product options



AZ 1033



#### Colour Option



#### Product Dimensions

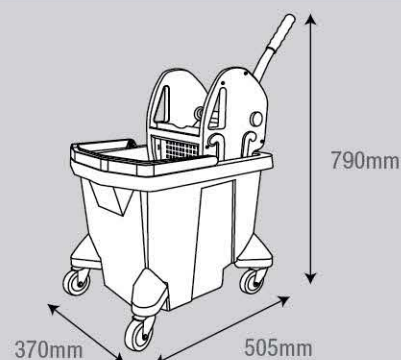





## Floor Safety

### Enhances floor safety to reduce the accidents

It is important to enhance floor safety by providing necessary floor safety equipment such as anti-slip mats and caution signboard to the visitors and employees in order to reduce the accidents. Anti-slip mat feature anti-skid surface to prevent slip and fall. Caution signboards feature highly visible and noticeable safety signal warning able to draw the attention of visitors and employees.

## AZ 1100 Anti Slip Mat

### Product Info

- Ideal use for wet and muddy environment
- Super heavy duty design.
- Anti-skidding surface to prevent slips and falls
- Water resistant and allow water spills and to be washed away through small holes on the surface

### Packaging

Quantity : 60 pcs / Carton  
 Carton Size : 636(L) x 323(W) x 396(H)  
 CBM : 0.081 / carton  
 Gross Weight : ± 33.33 kgs

### Specifications

Colour Available : Maroon, Dark Blue, Green, Grey, Light Green  
 Material : PVC  
 Product Dimensions : 300(L) x 300(W) x 12(H)

### Product Dimensions

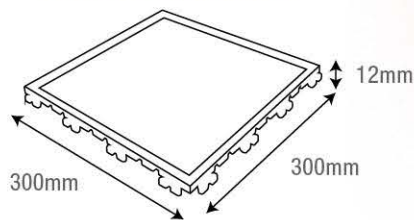

AZ 1100 Anti Slip Mat

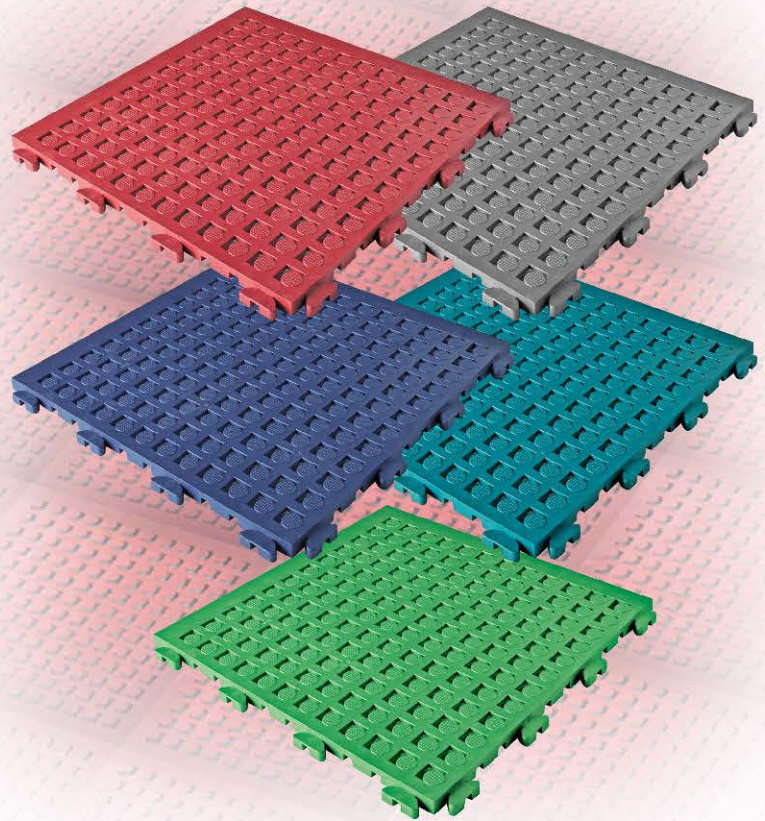

### Colour Option



▲ Maroon

▲ Green

▲ Dark Blue

▲ Grey

▲ Light Green





# Floor Safety



## Enhances floor safety to reduce the accidents

It is important to enhance floor safety by providing necessary floor safety equipment such as anti-slip mats and caution signboard to the visitors and employees in order to reduce the accidents. Anti-slip mat feature anti-skid surface to prevent slip and fall. Caution signboards feature highly visible and noticeable safety signal warning able to draw the attention of visitors and employees.

### AZ 1012 / 1038 Yellow Sign Board

#### Product Info

- Bright yellow sign board is rendered visible and easily draw attention
- Heavy duty design
- Clear caution message to reduce accidents or near misses
- Made from 100% virgin material
- **Wording customization available**

#### Packaging

- Quantity : 10 pcs / Carton
- Carton Size : 683(L) x 310(W) x 400(H)
- CBM : 0.085 / carton
- Gross Weight : ± 11.7 kgs

#### Specifications AZ 1012 (Big)

- Colour Available : Yellow
- Material : PP
- Product Dimensions : 295(L) x 31(W) x 670(H)

#### Specifications AZ 1038 (Small)

- Colour Available : Yellow
- Material : PP
- Product Dimensions : 295(L) x 31(W) x 590(H)

#### Product Dimensions

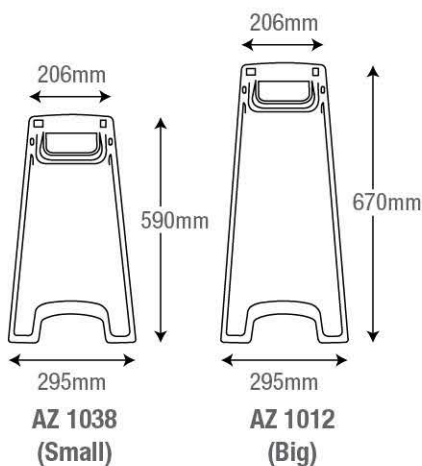

<p><b>FS 001</b></p> <p>Side A Side B</p>	<p><b>FS 002</b></p> <p>Side A Side B</p>	<p><b>FS 003</b></p> <p>Side A Side B</p>
<p><b>FS 004</b></p> <p>Side A Side B</p>	<p><b>FS 005</b></p> <p>Side A Side B</p>	<p><b>FS 006</b></p> <p>Side A Side B</p>
<p><b>FS 007</b></p> <p>Side A Side B</p>	<p><b>FS 008</b></p> <p>Side A Side B</p>	<p><b>FS 009</b></p> <p>Side A Side B</p>
<p><b>FS 010</b></p> <p>Side A Side B</p>	<p><b>FS 011</b></p> <p>Side A Side B</p>	<p><b>FS 012</b></p> <p>Side A Side B</p>
<p><b>FS 013</b></p> <p>Side A Side B</p>	<p><b>FS 014</b></p> <p>Side A Side B</p>	